

Introduction to Engine Repair – Study Guide

©2007 Melior, Inc.

Introduction

The engine is the power plant of a vehicle. Automotive engines have gone through tremendous changes since the automobile was first introduced in the 1880s, but all combustion engines still have three requirements that must be met to do their job of providing power – air, fuel, and ignition. The mixture of air and fuel must be compressed inside the engine in order to make it highly combustible and get the most out of the energy contained in the fuel mixture. Since the mixture is ignited within the engine, automobile power plants are called **internal combustion** engines. Most can be further classified as **reciprocating piston** engines, since pistons move up and down within cylinders to provide power. This up-and-down motion is converted into turning motion by the crankshaft.

Some of the main engine components

This course will provide an introduction to automotive engines and engine repair. Subjects covered will include:

- Major engine components
- Engine classifications
- The four stroke cycle and other engine design operations
- Engine construction
- General engine mechanical diagnosis
- Engine removal and installation
- Cylinder head and valve train diagnosis and repair
- Engine block assembly diagnosis and repair

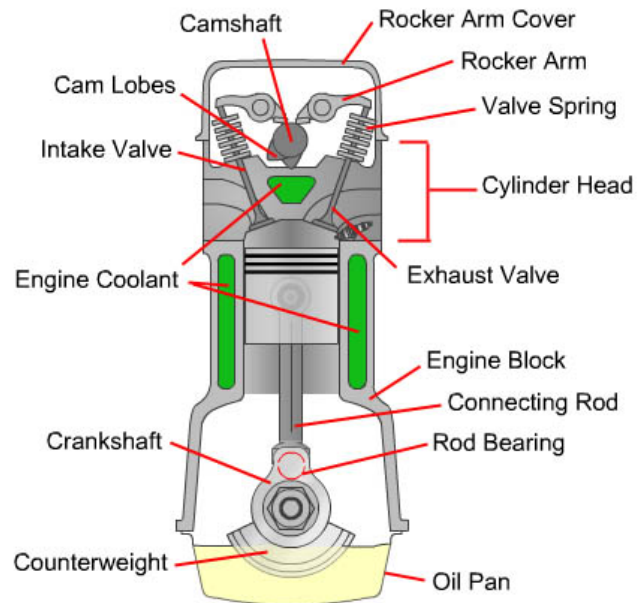

Unit 1 - Basic Engine Parts and Operation

Unit Objective:

After completion of this unit, students should be able to identify internal combustion engine components and their modes of operation.

Specific Objectives:

- Identify engine design associated terms and definitions
- Identify internal combustion engine components
- Understand and be able to explain basic internal combustion engine operation
- Identify common internal combustion engine design classifications

A small engine, such as one found in a lawn mower, usually contains only one cylinder and piston. Automotive engines use a number of cylinders to produce sufficient power to drive the wheels, but operate much like a small engine in many ways. Let's look at one cylinder of an engine to see how the main parts work together.

Engine Block

The block, highlighted at right in grey, is a heavy metal casting, usually cast iron or aluminum, which holds the lower parts of the engine together and in place. The block assembly consists of the **block**, **crankshaft**, **main bearings and caps**, **connecting rods**, **pistons**, and other components, and is referred to as the **bottom end**. The block may also house the camshaft, oil pump, and other parts. The block is machined with passages for oil circulation called **oil galleries** (not shown) and for coolant circulation called **water jackets**.

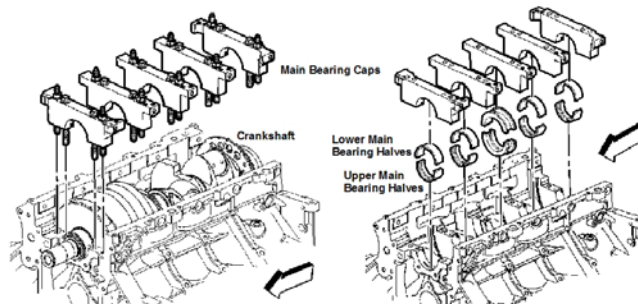

Cylinders

The cylinders are round holes or **bores** machined into the block for the pistons to travel up and down in.

Pistons

Combustion pressure acts upon the tops of the pistons in the cylinders, forcing them downward. Usually made of aluminum, the pistons transmit the downward force to the connecting rods. The top of the piston's travel is called Top Dead Center (TDC) and the bottom of a piston's travel is called Bottom Dead Center (BDC).

Piston Rings

Rings are installed in grooves around the pistons to form a seal between the piston and the cylinder wall. Two types of rings are used: **compression rings**, which prevent combustion pressure from entering the crankcase, and **oil control rings**, which prevent engine oil from entering the **combustion chamber** above the piston. Oil rings scrape excess oil from the cylinder walls for return to the crankcase.

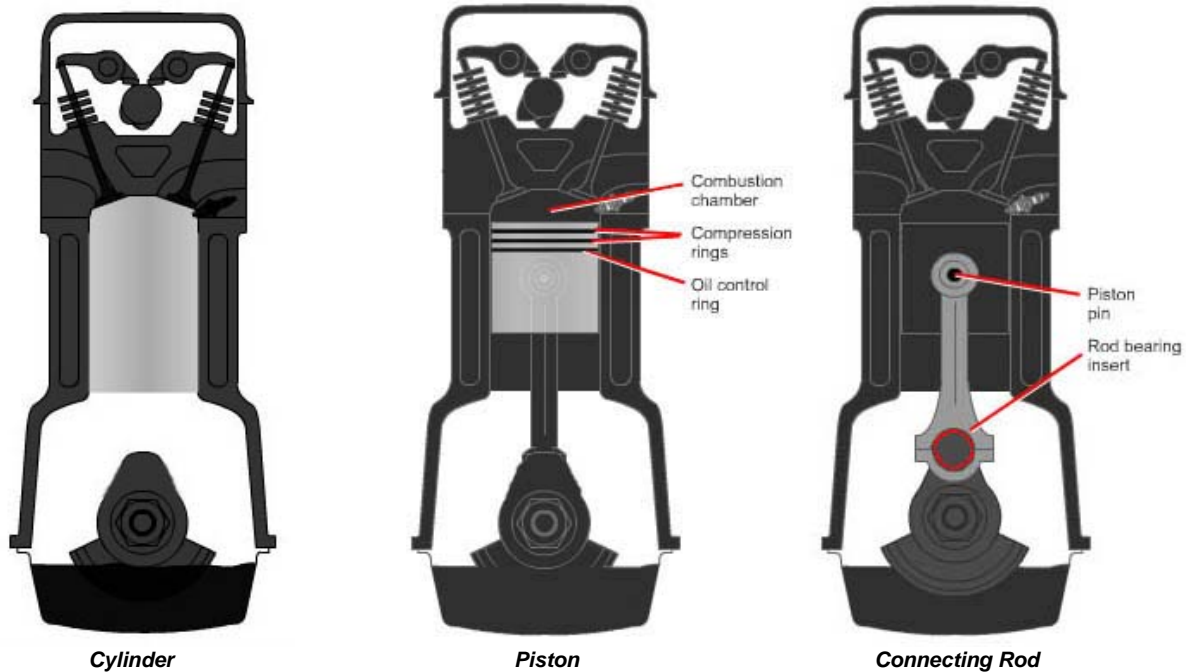

Connecting Rods

A rod connects each piston to the crankshaft. The small, upper end of the rod commonly has a bushing pressed into it. A **piston pin**, or **wrist pin**, attaches the piston to the rod through this bushing, which allows the rod to pivot as needed. The larger, lower end of the rod is attached to the crankshaft through **rod bearing inserts** that are stationary relative to the rod and allow the crankshaft to turn within the rod on a film of oil.

Crankshaft

The crankshaft is a strong, alloyed iron or steel shaft that converts the up-and-down motion of the pistons into a turning motion that can be transmitted to the drive train. The crankshaft is supported by the block in several places along its length. The crankshaft rides in **main bearings**, which are inserts similar to the rod bearings at these supports. Where the crankshaft is connected to the rods and where it is supported by the block are called **journals**. The crank is finely machined and polished at these places. The crankshaft is also drilled with a network of oil passages to deliver oil under pressure to these places from the oil galleries. **Counterweights** are formed onto the crankshaft to help prevent vibration.

These weights are added to offset the weight of the piston and connecting rod assemblies. At the front of the crankshaft, outside the engine front cover, a heavy wheel containing a rubber vibration damper is installed. Also called a **harmonic balancer**, it often incorporates the crank drive belt pulley, which powers belt-driven accessories. At the rear of the crankshaft, a large **flywheel** is mounted. The flywheel can serve several purposes: a ring gear is mounted to its circumference to provide a means to start the engine. It also connects the engine to the transmission. Finally, on vehicles with manual transmissions, the flywheel is made very heavy to help smooth out power pulses from the engine (this is accomplished by the torque converter on vehicles equipped with automatic transmissions).

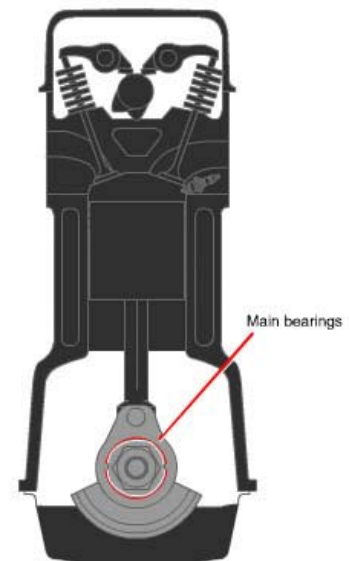

Crankshaft

Cylinder Head

Like the engine block, cylinder heads are usually cast from either iron or aluminum. Most V-type, opposed, and W-type engines have two cylinder heads. Inline engines have only one cylinder head. The head bolts to the top of the block, covering and enclosing the tops of the cylinders. The head forms small pockets over the tops of the pistons called **combustion chambers**. The **spark plugs** are threaded into holes in the head and protrude into the combustion chambers (gasoline engines). **Intake ports and exhaust ports** are cast into the head, and small holes called **valve guides** are machined into it to position the valves. The **valves** act as gates. When open, they let air and fuel into the cylinder and exhaust gas out. When closed, they seal the pressure of compression in the combustion chamber. The valves close against machined, press-fitted inserts in the combustion chamber ports called **valve seats**. On overhead cam engines like the one pictured here, the head also houses the **camshaft**. The assembly, together with other valve train components and the intake and exhaust manifolds, is referred to as the **top end**. Between the head and the block, a **head gasket** seals the combustion chambers, and water and oil passages.

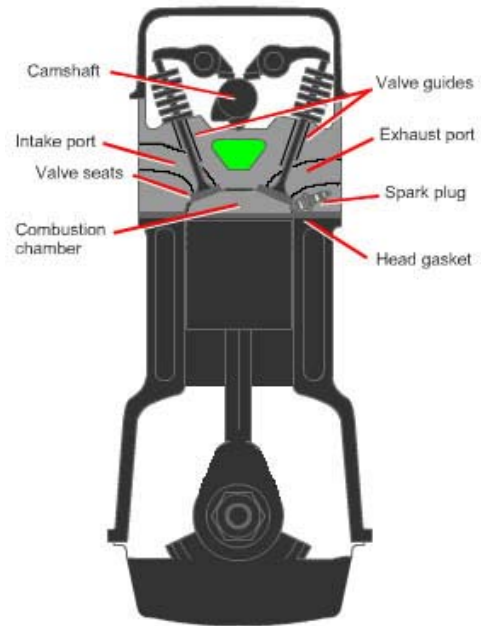

Cylinder Head

Valve Train

The valve train consists of the **valves**, **camshaft**, and other associated parts. The valves control the flow of the incoming air-fuel mixture and the outgoing exhaust gasses. The **intake valves** are larger than the **exhaust valves**, and many engines today have two intake and two exhaust valves per cylinder to improve efficiency and performance.

Like the crankshaft, the camshaft rides on a film of oil as it rotates on journals. Rotation of the camshaft opens the valves, and **valve springs** close them. The camshaft has carefully machined high spots called **lobes** that act upon the valves (or other parts) to open each valve at precisely the right time. As the lobe moves away, the spring closes the valve. Some engines have *dual overhead cams* (DOHC), with a cam for the intake valves and one for the exhaust valves. The engine shown here uses a *single overhead cam* (SOHC).



Timing Gears and Belt

Valve Train

Engines with the camshaft located in the block are called **pushrod engines**, because long pushrods are used to transmit the camshaft's movement up to the **rocker arms**, which rock to open the valves. On these engines, the cam acts on a valve lifter, which in turn acts on a pushrod to move the rocker arm and open the valve. We will examine this arrangement later. Overhead cam engines may have a set of parts called valve followers, which operate like lifters. Some engines have a gear on the camshaft to drive the ignition distributor and oil pump, and some diesel engines and older gasoline engines have a rounded lobe on the camshaft to drive a mechanical fuel pump.

The engine top end and bottom end must be timed together so that the valves will open and close at the proper times for the positions of the pistons, and this is accomplished through the camshaft drive. The camshaft is driven by a sprocket gear mounted on the front of the crankshaft.

The sprocket either meshes with a sprocket on the front of the camshaft, or, more often, the two sprockets are linked by a belt or a chain. In the engine shown here, **timing gears** and a **timing belt** are used. Both sprockets must be installed with their timing marks aligned in the proper positions in order to time the engine.

The Four-Stroke Cycle (Otto Cycle)

A **stroke** is one movement of the piston either down from Top Dead Center (TDC) to Bottom Dead Center (BDC), or up from BDC to TDC. The term "stroke" also refers to the physical distance between these two points. One stroke of the piston moves the crankshaft through one-half of a revolution. Almost all engines on the road today operate on a cycle of four piston strokes. The strokes are the **intake stroke**, **compression stroke**, **power stroke**, and the **exhaust stroke**. This cycle turns the crankshaft through two revolutions and then the process begins again.

Intake Stroke

The process begins with the intake stroke. The piston moves down from top dead center (TDC) to bottom dead center (BDC). The movement of the piston creates a partial vacuum, drawing air and fuel into the cylinder through the open intake valve. The ideal air-fuel mixture for performance, economy and emission control is 14.7 parts air to 1 part fuel. On Throttle Body Injection (TBI) systems and old carbureted systems, fuel is carried in the air stream through an intake manifold and into the intake port. On Multiport Fuel Injection (MPI) systems, each cylinder has its own injector, which allows fuel to be injected into the port with more precision and uniformity than possible with Throttle Body systems. During this stroke, the exhaust valve remains closed.

Compression Stroke

After the piston passes BDC, the compression stroke begins. The intake valve closes and the mixture in the cylinder is compressed by the piston as it moves upward again to TDC. The intake and exhaust valves are both closed during this stroke, so the pressure and temperature of the air-fuel mixture rises. A typical compression ratio for a gasoline engine might be 9:1. The compression ratio is the volume of the cylinder, including the combustion chamber, with the piston at BDC compared to the volume with the piston at TDC. The crankshaft has now made one revolution.

Power Stroke

This is what it's all about! As the piston nears TDC with both valves closed, the compressed air-fuel mixture is ignited. Combustion occurs, resulting in a tremendous pressure increase that pushes the piston back down the cylinder. This is the power or "working" stroke. The intake and exhaust valves remain closed. In an idling engine, this happens in each cylinder about five times a second and running at 4,000 RPM it happens over 30 times a second!

Exhaust Stroke

Now, the spent gasses must be removed from the cylinder to make room for the next air-fuel charge. The exhaust stroke begins as the piston nears BDC. The exhaust valve opens and the piston moves upward again, pushing the burned exhaust gases out of the cylinder. The intake valve remains closed until the piston has almost reached TDC again. At this point, the engine has completed one full cycle, and the crankshaft has rotated twice. The entire process then repeats.

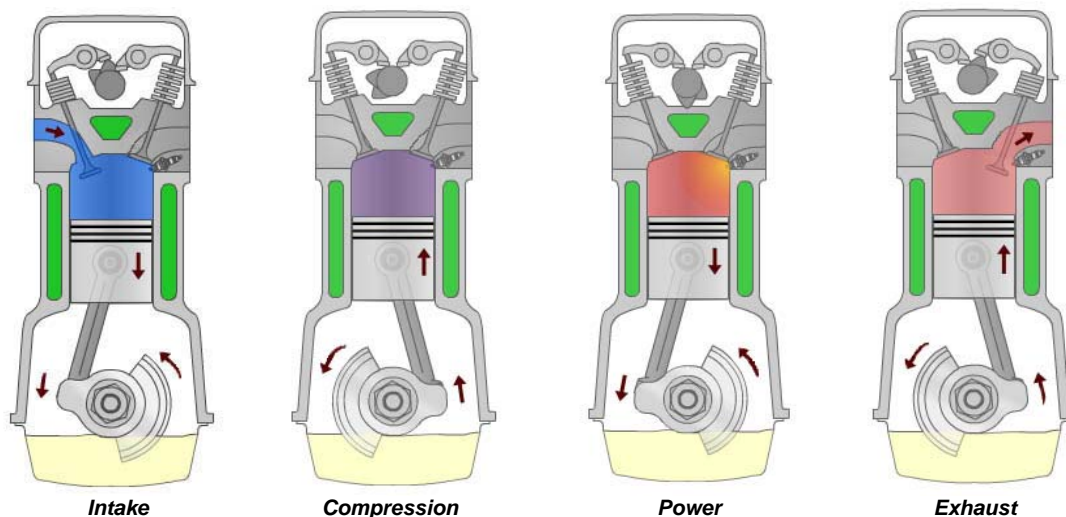

Other Engine Designs

While the vast majority of automobile engines are gasoline-powered, four-stroke reciprocating piston engines, other engine designs have been developed and used in automobiles, some quite successfully. Additionally, changing economic, environmental, and political conditions have created a demand to modify or retire this proven workhorse with new or re-worked designs. As materials and technologies improve and evolve, some of these contenders may come into common use in automobiles.

Two-Stroke Cycle Engines

A two-stroke cycle engine is another reciprocating piston design. Every downstroke delivers power in this design, and it has no valve train. Instead, in a conventional two-stroke gasoline engine, the air-fuel and exhaust gas are managed by the piston as it covers and uncovers intake and exhaust ports in the side of the cylinder. It also has no oil sump or pressurized oil delivery system, because the crankcase is part of the fuel delivery system. Instead, the crankcase is lubricated by mixing a small amount of oil with the fuel. Being able to deliver power with every downstroke and not having a heavy valve train means the two-stroke engine can provide a lot of power for its size and weight. Two-stroke engines have been used for many years in small engine applications such as outboard boat engines, motorcycles, ultralight aircraft, chainsaws and lawn equipment, etc. Some two-stroke engine automobiles have been imported to the U.S., and many medium and heavy duty diesel applications are currently equipped with two-stroke engines.

Unfortunately, the light weight and simplicity come at a price. Conventional two-stroke gasoline engines produce higher exhaust emissions and yield lower fuel economy than a comparable four-stroke engine. This is largely due to the burning of the oil in the

combustion chamber and leakage of unburned fuel inherent in the engine's design. The causes of this will be clearer when we examine the operation of the engine. Nevertheless, the two-stroke engine has received renewed interest in recent years, as innovations and advancements in fuel injection, materials, and engine management systems develop. These engines have a pressurized lubrication system, fuel injectors, and superchargers that compress the intake air, similar to a two-stroke diesel engine.

The Two-Stroke Cycle

We'll begin the explanation of the two-stroke cycle with the firing of the spark plug, which occurs before every downstroke. As the piston moves down, delivering power, the intake and exhaust ports are both covered. At the same time, the downward movement of the piston is pressurizing the crankcase with the next air-fuel charge, which was drawn into the crankcase through the air-fuel inlet and around the reed valve. This pressure forces the reed valve to close. As the piston continues downward, it uncovers the exhaust port. Remaining combustion pressure begins to blow the spent gas out the port. Further downward movement uncovers the intake port as well, and both ports are open for an instant, as the pressurized air-fuel charge from the crankcase enters the cylinder. The incoming air-fuel purges the remaining exhaust gas from the cylinder. As the piston travels upward again, it covers the intake and exhaust ports so compression can begin. At the same time, the piston's movement creates a vacuum in the crankcase, opening the reed valve again and drawing in the next air-fuel charge.

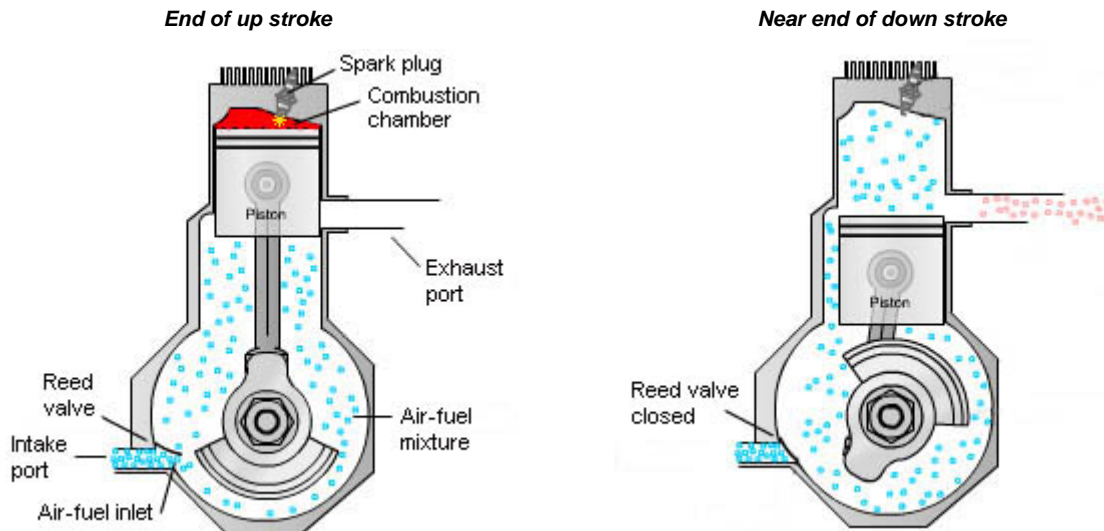

Diesel Engines

The diesel engine is another reciprocating piston design. Diesel engines in passenger cars and light trucks operate on the four-stroke cycle, but they have important differences from the gasoline engines we have discussed. The most significant difference is the way in which diesel engines ignite the fuel. Rather than using a spark to start the combustion, a diesel engine uses the heat produced by compression of the air in the cylinder. Diesel engines must compress the air much more than a gasoline engine does – about twice as much – in order to produce enough heat to ignite the fuel. **Compression ignition** engines such as diesels must be designed heavier and stronger than **spark ignition** engines to withstand the compression and combustion produced in the cylinders. These engines have steel sleeves pressed into their cylinder bores.

All diesel engines use fuel injectors to deliver the fuel to the combustion chambers at just the right time. If the fuel were delivered along with the air, as in a gasoline engine, the fuel would ignite prematurely. The fuel pressure at the injectors must be very high to overcome the pressure in the combustion chambers created during the compression stroke. Keep in mind that with the port fuel injection systems on gasoline engines, the fuel is injected outside the combustion chamber near the intake port and drawn into the cylinder on the intake stroke.

Other significant differences between gasoline and diesel powered engines are the result of differences in the fuels they burn. Diesel fuel is an oil, and as such, it is thicker, heavier, and less volatile than gasoline. However, there is more energy contained in a gallon of diesel fuel than in a gallon of gasoline. While a gasoline engine can produce more power by weight than a diesel engine, the diesel engine runs much leaner and provides better fuel efficiency by about one-third. This has made diesel engines attractive to automobile manufacturers at times, but these engines have other drawbacks that have prevented them from taking over in passenger cars. High exhaust emissions of particulates (soot) and oxides of nitrogen (NO_x) due to the high

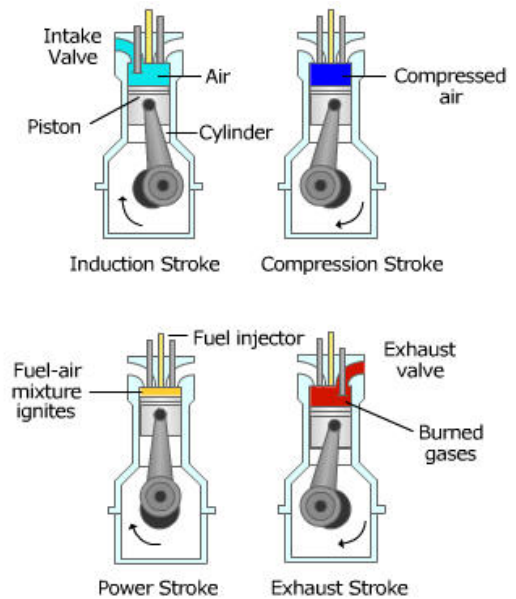

Diesel Engine

combustion temperatures are an obstacle. Difficulty in starting diesel engines in cold weather, sluggish acceleration, smell, and noise are other factors that have prevented diesels from being widely used in automobiles, but this may change again in the future.

Rotary Engines

The rotary engine is one of the few mass-produced automobile engines that is not a reciprocating piston design. Instead, combustion directly causes the rotation of rotors within a chamber. This design can produce a very powerful, smooth-running engine with fewer moving parts than a piston engine, and it can operate at higher RPM.

Rotary Engine -
Movement of the rotor produces a low pressure area at the intake, drawing in the air-fuel mixture. Further rotor movement compresses the mixture and it is ignited. The resulting power pulse pushes on the rotor. The rotor continues turning to expel the exhaust gas. Three power pulses are produced for every revolution of the rotor.

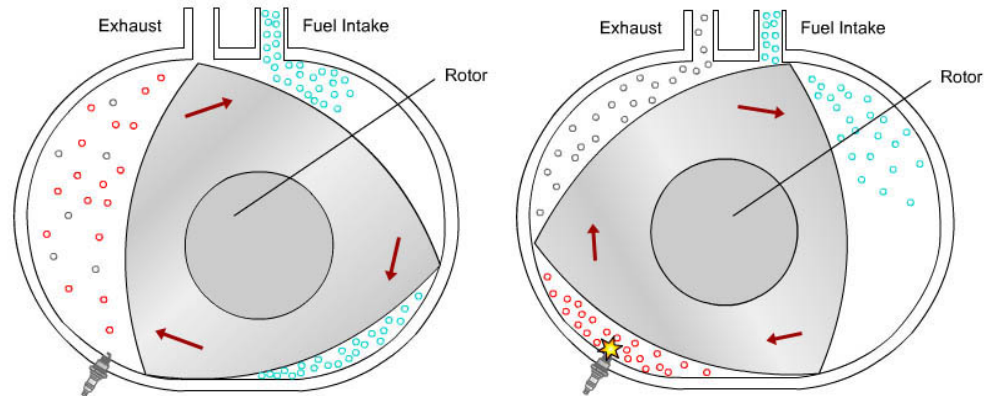

Engine Classifications

Engines can be classified in many different ways, according to their design characteristics and operation. These differences can affect the methods of maintenance and repair. Some ways engines can be classified are:

- **Operational design** (four-stroke, two-stroke, rotary, etc.)
- **Number of cylinders** (four, five, six, eight, 12, etc.)
- **Arrangement of cylinders** (V-type, inline, etc.)
- **Displacement** (3.8 liter, 3800 cubic centimeters, 5.0 liter, 350 cubic inches, etc.)
- **Number of valves and valve train type** (overhead cam, pushrod, 24-valve, etc.)
- **Ignition type** (spark or compression, spark distribution system, etc.)
- **Cooling system** (air or liquid)
- **Fuel type** (gasoline, diesel, propane, etc.)

We have already discussed operational design, but the other classifications may need explanation.

Number and Arrangement of Cylinders

Automobile engines can have three, four, five, six, eight, 10, or 12 cylinders. More cylinders mean more power strokes per revolution of the crankshaft, which provides more power and smoother running. The cylinders can be arranged in a number of ways. The three most common cylinder configurations are **inline**, **V-type**, and **opposed**.

Engines with even numbers of cylinders have pairs of **companion cylinders**, in which the pistons move up and down together. When one of the pistons is on its power stroke, the other one will be on its intake stroke. Likewise, when one piston is on its exhaust stroke, its running mate will be on its compression stroke.

Inline engines have all their cylinders in a straight row. This is a common arrangement for four-cylinder engines and inline six-cylinder engines are still produced. Many years ago, inline eight-cylinder engines were produced, but there are several problems associated with an engine of that length.

V-type engines have two cylinder banks, a left bank and a right bank, at an angle to one another such that when viewed from the front or rear, the block forms the shape of a "V". As with all matters of automotive service, left and right are referenced from the vantage point of someone sitting in the vehicle. V-6 and V-8 engines are common, while a few V-10 and V-12 engines are produced. The V-6 has several advantages over inline-6 engines. The V-type is more space- and weight-efficient. Two connecting rods from opposing banks share one crank pin (rod journal).

An Inline Four-cylinder Engine

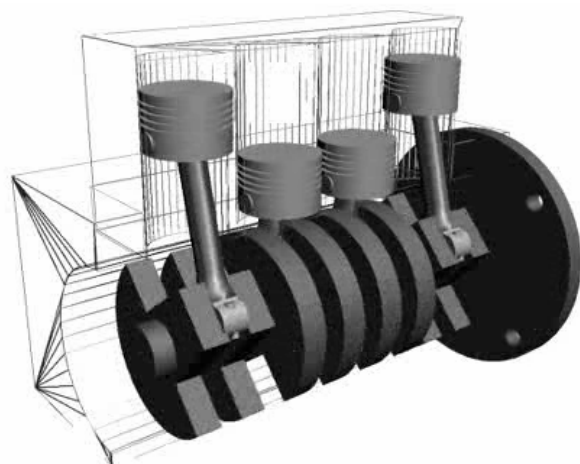

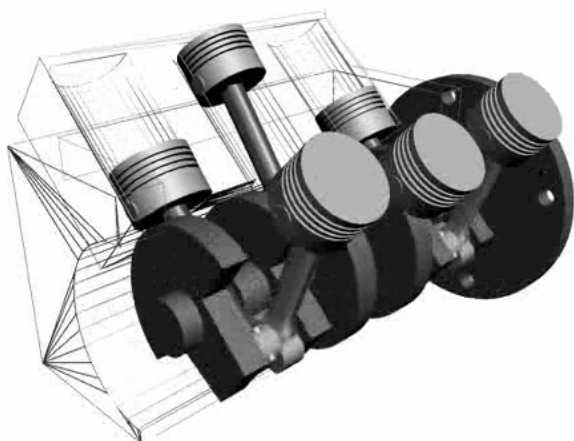

A V-6 Engine

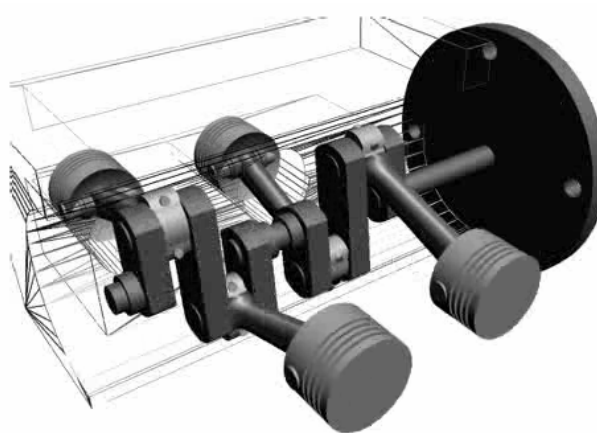

An Opposed Four-cylinder Engine

Opposed engines have cylinders that face each other from opposite sides of the crankshaft. This arrangement is sometimes called a boxer or pancake engine, because the cylinders lay flat, giving the engine a low profile. This makes it suitable for rear- and mid-engine applications, and this type of engine has been used in Porsches, Volkswagens (air-cooled), and Subarus.

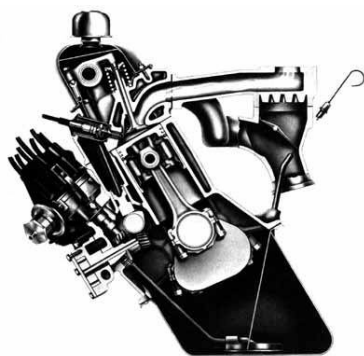

Chrysler Slant Six Engine

A **slant** arrangement has also been used. This arrangement is a variation on the inline design, and some manufacturers have used it to lower the hood line. It sets in the engine compartment at a slant, and may resemble "half" of a V-type engine. A few high-end automakers have produced engines with 16 cylinders in a "W" arrangement, but with a price of around one million dollars for the vehicle, you are unlikely to see one in a typical shop. The "W" arrangement is done to conserve space.



W-Type

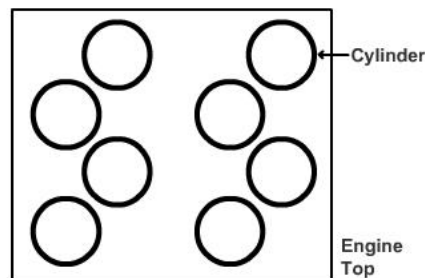

The cylinders are assigned numbers by the manufacturer for reference. The numbering system varies by manufacturer. Sometimes the numbers are stamped into the intake manifold. The **firing order** is the sequence in which the spark plugs fire, and is usually different from the order of the cylinder numbers. The firing order may also be stamped on the intake manifold, but both sets of numbers are available in the service information for the vehicle. The firing order will vary among manufacturers or divisions.

Displacement

Commonly called "engine size," the displacement of an engine is the volume of all the cylinders added together. In the U.S., engine displacement was expressed in cubic inches for many years. In modern vehicles, displacement is usually given in liters (L) or cubic centimeters (cc).

The diameter of the cylinder is called the **bore**. If the bore and the length of the piston stroke are known, the volume of a cylinder can be calculated. The simplest formula for calculating the volume of a cylinder is:

$$\text{Bore}^2 \times \text{Stroke} \times 0.7854 = \text{cylinder volume}$$

This result is multiplied by the number of cylinders to arrive at the displacement of the engine. The value of 0.7854 is pi /4. Using the formula to determine the displacement of a six-cylinder engine with a bore of 10cm and a stroke of 8cm, we find:

$$100 \times 8 \times 0.7854 \times 6 = 3,769.92$$

This would be expressed as 3770cc, or approximately 3.8L.

Number of Valves and Valve Train Type

In an earlier section, we saw the operation of an engine with a single overhead cam. We noted that a **dual overhead cam** (DOHC) engine has a cam for the intake valves and one for the exhaust valves. A V-type DOHC engine has four camshafts – two for each bank. Dual overhead cams are frequently used on engines that have more than two valves per cylinder. Four-cylinder engines

typically have eight, 12, or 16 valves. A six-cylinder may have 12, 18, 24, or 30 valves, and a V-8 may have 16, 24, 32, or some other number of valves.

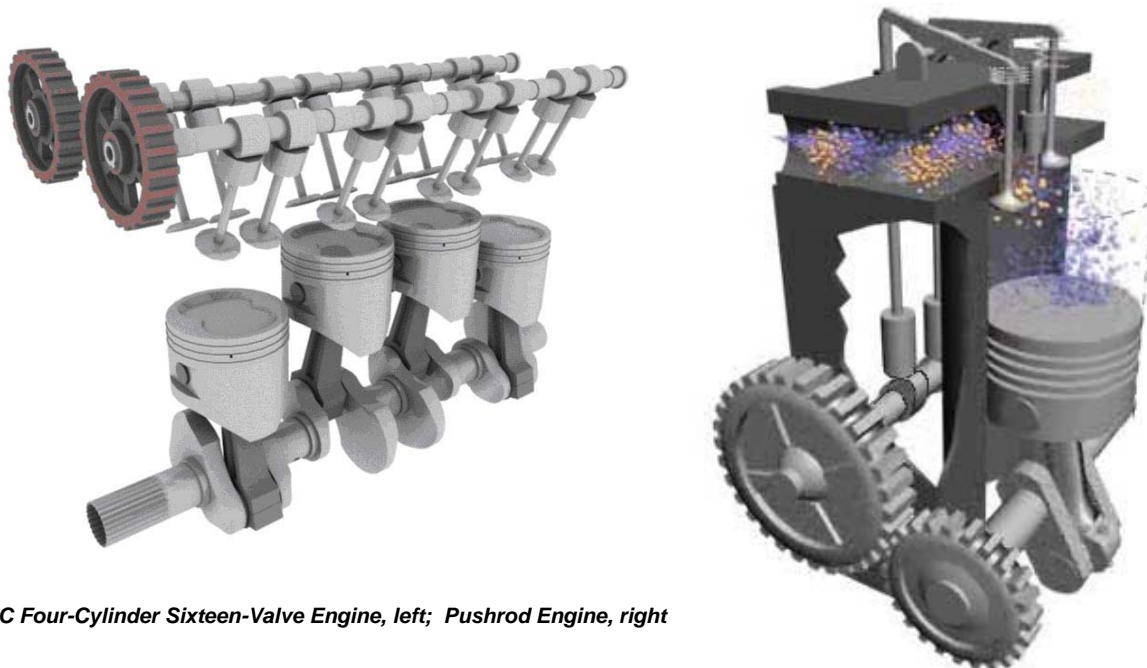

DOHC Four-Cylinder Sixteen-Valve Engine, left; Pushrod Engine, right

Pushrod engines (those with the cam in the block) are sometimes referred to as “overhead valve” engines to differentiate them from overhead cam engines, but all modern automobile engines use overhead valves. The term was originally used to distinguish the pushrod valve arrangement from engines that have the valves in the block, a design now found only in antique cars and some small engines.

In pushrod engines, the cam acts on a valve lifter, which in turn acts on a pushrod to move the rocker arm and open the valve.

Ignition Type

In our discussion of engine designs, we noted that there are two methods of igniting the fuel: **spark** and **compression**. Gasoline engines use a spark to ignite the fuel, while diesel engines have no spark plugs and use the heat of compression to ignite the fuel.

A further distinction can be made regarding spark ignitions systems, and that is whether they use a mechanical ignition distributor or not. Until 1984, all gas engines used a distributor driven by the camshaft to send a spark on its way to each cylinder at the proper time. These systems are now called **Distributor Ignition (DI)** systems. Today, most engines produced are distributorless and rely on engine sensors and electronic components to accomplish this task. These systems are called **Electronic Ignition (EI)** systems. Note that for a time, these were referred to as Distributorless Ignition Systems (DIS). Note also that distributor systems since the mid-1970s have used electronic components and were once referred to as “electronic ignition.” Ignition systems are discussed in the Engine Performance module.

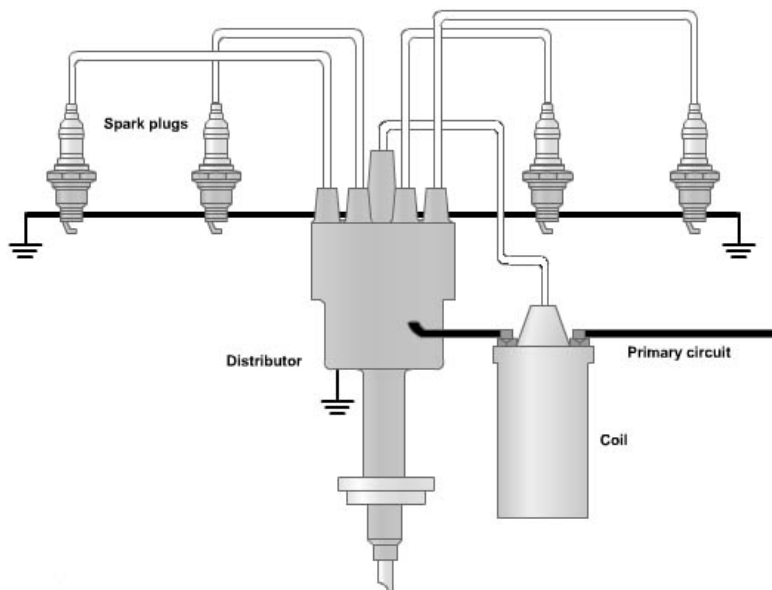

Distributor Ignition

Cooling System Type

Engines are either **air-cooled** or **liquid-cooled**. Nearly all automobiles currently in production have liquid-cooled engines. Air-cooled engines can be found in motorcycles, lawn mowers, and some automobiles. Cooling fins cast on the outside of engine parts, especially the cylinders and heads, increase surface area and help dissipate heat into the air flowing around them. Air-cooled engines run at higher temperatures than liquid-cooled engines under some conditions, and they can't maintain as constant a temperature. This causes an exhaust emissions problem (especially oxides of nitrogen) that has limited their production in recent years.

In liquid-cooled engines (often called "water-cooled"), a pump circulates coolant through cavities and passages called water jackets around the cylinders and combustion chambers. A thermostat keeps the engine at the optimum operating temperature by controlling the coolant flow between the engine and the radiator, where the heat is given off to the air passing through it. The coolant is normally a mixture of 50% water and 50% antifreeze. The antifreeze provides protection against freezing, boiling, and rust and corrosion, and provides lubrication and seal conditioning. Cooling system operation and service is covered in the Today's Class HVAC course.

From this point on, this course will deal with gasoline powered, liquid-cooled four-stroke piston engines.

Unit 2 – Engine Mechanical Diagnosis

Unit Objective:

After completion of this unit, students should be able to perform procedures for general engine mechanical diagnosis and testing.

Specific Objectives:

- Identify general engine diagnosis associated terms and definitions.
- Understand and be able to explain the procedures for:
 - identifying and interpreting engine concerns
 - performing a preliminary engine inspection
 - evaluating engine noise
 - diagnosing excessive oil consumption
 - diagnosing oil pressure problems
 - inspecting, removing, and installing engine covers
 - performing engine vacuum tests
 - performing cylinder power balance tests
 - performing engine compression tests
 - performing cylinder leakage tests

Mechanical Diagnostics

Engine mechanical problems can have many causes. Component wear is both normal and inevitable. Anything with moving parts will wear with prolonged operation. This wear can occur sooner than expected if an engine is abused or is improperly maintained. Sealing gaskets can split or leak, internal engine parts such as piston rings, bearings, and valvetrain components can wear, and intake and exhaust valves can burn, just to note a few common examples.

Typical Engine Component Wear Areas

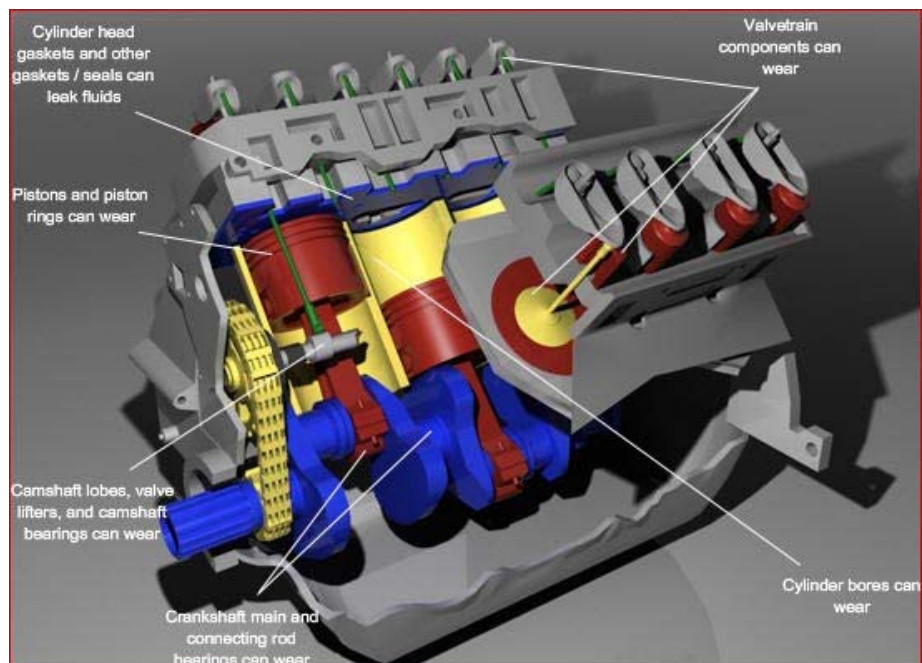

Improper Service

Improper service can cause engine mechanical problems and increased wear as well. For example, cleaning gasket surfaces with surface conditioning disks is NOT recommended by vehicle manufacturers. The use of such surface conditioning discs dislodges Aluminum Oxide (from the disk) and metal particles, which can lead to premature engine bearing failure. In some cases, this failure occurs in as little as 1,000 miles (2,200 km) after the repair has been made.

Improper bolt torque when reassembling engine components can distort bearing or sealing surfaces when fasteners are overtorqued. Undertorqued fasteners can loosen and cause problems ranging from fluid leaks to major engine failure when an engine component comes apart while running.

To effectively diagnose the wide range of possible engine mechanical problems requires more study than can be provided in this introductory course; however, some basic diagnostic information and testing methods will be provided to help you get started. Understanding some of the test methods included will also help in your understanding of how an engine works, why it works, and what happens when it doesn't work properly.

A logical, step-by-step approach should be developed and used in diagnosing all automotive systems. A systematic approach will save time and ensure that the proper repairs are made.

Verifying the Customer's Concern

Effective communication between the customer, service writer, and technician is essential for efficient and satisfactory repairs. To begin with, you must know the correct or normal operation of the system and verify that the customer concern is a deviation from normal operation. You need to know what, where, when, and the magnitude of the complaint. This may necessitate a road test. Try to have the vehicle owner/driver ride along during the road test. The owner/driver can assist in identifying the source of any problems. Remember that you will not always be able to verify or even identify each and every customer concern.

- ***Always check engine oil and coolant levels prior to running the engine or road testing!***
- ***Safety first when road testing – NEVER drive in an unsafe manner when attempting to identify a problem!***

Information Gathering

In identifying and verifying the customer's concern, you are actually gathering information from both the customer and from the vehicle itself. This process of gathering information is an essential step in forming a diagnostic strategy that in turn will identify the cause of the customer concern. Once you've gathered information from the customer and the vehicle, the next step is to research service information related to the owner/driver's concern. Service manual information and technical service bulletins (TSBs) should be searched and read to familiarize yourself with the system. TSBs may also contain information on updated parts and service procedures related to your customer's concern.

Another part of information gathering, even when dealing with engine mechanical issues, is using a scan tool. Stored Diagnostic Trouble Codes can provide useful information, as can control module calibration or software identification numbers. Ideally, this step should be performed during the road test. It should be done before researching service information.

Determine a Diagnostic Direction

Based on the information that you've gathered, you now should be able to determine what diagnostic procedures should be performed to locate the concern.

Here's a real-world example of this process. A regular customer brings you a 1994 Buick Century with a 3100 V6 (VIN M) engine. The odometer in this vehicle shows 65,000 miles. This customer states that within the last month the vehicle has suddenly begun consuming oil at a rate of a quart every 500 miles. Your shop has serviced this vehicle regularly, so you have the vehicle's service history. As a part of the information gathering process, you find GM TSB # 87-60-03 while researching manufacturer's technical service bulletins. This technical service bulletin identifies lower intake manifold gaskets as being a potential cause for your customer's concern. The bulletin also describes how to verify the customer complaint and even gives part numbers for updated gaskets that should be used in making the repair.

Keep in mind that your customer's vehicle still needs to be properly diagnosed. The TSB in this example tells you how to perform the diagnosis to either confirm or rule out failed intake manifold gaskets as being the cause of the customer complaint.

Preliminary Engine Inspection

Even after determining a diagnostic path or direction, a preliminary inspection of the engine should be performed. This may reveal other areas that need service or that may be contributing to the customer complaint. Preliminary checks should include a **visual inspection** and confirmation. Your inspection should include listening for unusual sounds, looking for sources of fluid leaks, and checking for unusual odors. The vehicle service history can provide useful information as well.

Evaluating Engine Noise

Unusual noises can be indicators of engine damage or wear. Pinpointing and evaluating engine noise is a very difficult diagnostic job. It is important to attempt to locate the area where the noise appears to be coming from before tearing the engine apart. Noise is sometimes transmitted to other locations, and can often be difficult to isolate. Practice and experience will make this process easier over time. A technicians' stethoscope, or probe, can be helpful in successfully locating and evaluating engine noise. The stethoscope can be moved around until the exact location of the noise is determined. If a stethoscope is not available, a long, thin screwdriver, or a piece of hose can sometimes be substituted.

- **Use extreme caution when using a stethoscope or long screwdriver around electrical connections and moving parts.**

Identifying Engine Sounds

Note that it would be impossible given the scope of this course to attempt to list every possible sound from every type of engine. The following section is designed to show common causes of abnormal engine sounds.

Rod Knock: A worn, loose connecting rod bearing causes the big end of the rod to hammer on the rod journal of the crankshaft as the piston moves up and down. This hammering makes a knocking sound. The rod bearing knock sounds loudest at the lower part of the engine, and it may change at a particular engine speed or load.

When the engine is cold, the oil is thicker. The knock may be quieter or even absent as a result. As the engine warms up, the oil thins out. This may make the knock more noticeable.

Sometimes killing fuel or spark to one cylinder at a time while the knock is at its loudest will temporarily quiet the knock or make the knock sound change. This will enable you to identify which rod bearing is knocking. This test may not be conclusive when rod bearings are extremely worn.

During a road test, the rod bearing knock may be speed sensitive, becoming quieter as engine speed and load is increased or decreased. When rod bearing noise becomes more severe, it will tend to lose this speed sensitivity.

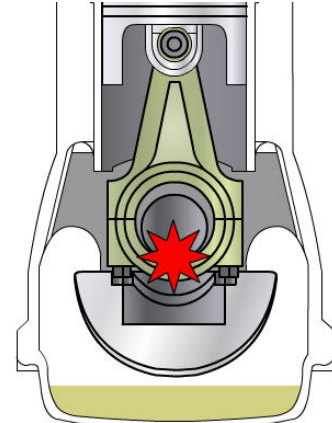

Rod Knock

- **Always use factory-approved methods when interrupting or stopping spark or fuel on a running engine for safety and to minimize the chance of engine or component damage!**

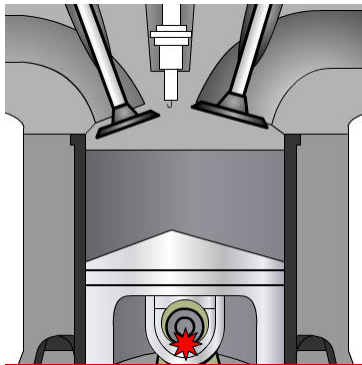

Piston Pin Knock

Piston Pin Knock: Excessive clearance at the other (small) end of the connecting rod can cause a knock as well. A knock at the piston (wrist) pin sounds somewhat like a rod bearing knock but will be located much higher in the engine than the rod knock. It also may or may not be sensitive to changes in engine speed, load, or temperature.

In some cases, the location of the knock may be the only way to determine if it is coming from a rod or from a piston pin. In other cases, the rod bearing and piston pin produce two different types of noise.

- **Distinguishing between a wrist pin knock and a rod bearing knock is not critical at this point in the diagnosis. Repairing either component requires engine disassembly and further inspection.**

Piston Slap: Piston slap is a knocking sound caused by a piston rocking in a worn cylinder bore and contacting the cylinder wall.

Piston slap sounds much like a wrist pin knock. However, unlike a wrist pin knock, a piston slap generally quiets down as the engine warms up and the piston expands. Sometimes killing fuel or spark to one cylinder at a time will temporarily make the piston slap get louder or change its sound. Correction of the piston slap also requires engine disassembly and measurement.

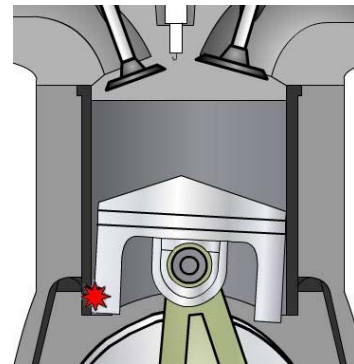

Piston Slap

Main Bearing Knock: A main bearing knock sounds more like a dull thud than a knock. A main bearing knock comes from lower in the engine. The knock is loudest when the engine is under a moderate to heavy load.

The cause is usually worn crankshaft main journals and/or worn main bearings allowing the crankshaft itself to flex under load. This in turn makes the crankshaft move up and down inside the cylinder block.

In addition to audible noise, loose connecting rod bearings or main bearings will usually cause low oil pressure. This low pressure will be more noticeable at slow engine speeds. This is because the oil pressure leaks off past the loose bearing. Slow engine speeds can compound this because the oil pump turns too slowly to overcome this leakage and maintain the proper pressure. At higher engine speeds, enough oil is pumped to overcome the leak and increase the oil pressure.

A sharp knock or a dull thud sound **and** low oil pressure together indicate worn connecting rod or main bearings. Diagnosing oil pressure problems will be discussed in the next section.

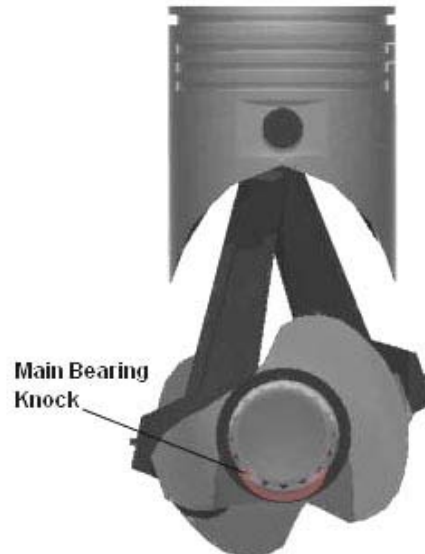

Timing Chain Rattle or Slap: Some engines use timing chains. A rattle sound coming from the front of the engine is usually the result of a loose or stretched timing chain. The chain will sometimes slap the timing cover or chain guide when the throttle is snapped.

With some engine designs, extremely loose timing chains can sometimes wear through the timing cover and cause an oil leak. If the timing cover contains coolant passages between the water pump and the block, (20R and 22R four cylinder Toyota engines, for example) a loose chain can wear through these passages as well. An internal coolant leak will cause coolant and engine oil to mix.

Loose Timing Chain

Valvetrain Noise: Excess clearance between valvetrain components sometimes produces a clicking or clattering sound that comes from high in the engine. This sound has a higher frequency than a bearing knock.

Causes of excessive clearance can include worn valvetrain components, a worn camshaft lobe, a bent pushrod, or misadjustment of valve clearance (in the case of manually adjustable valves). Valvetrain wear occurs with age and mileage. Abnormal wear can be a sign of a lubrication system problem such as insufficient or dirty oil or clogged oil passages. Keep in mind that replacement of worn components without correcting the lubrication problem may result in a repeat failure and comeback.

Non-engine related sounds: If the noise occurs only when changing gears or going into or out of gear, the engine itself may not be the problem. The engine mounts, transmission, torque converter flexplate or clutch should be checked for wear or breakage.

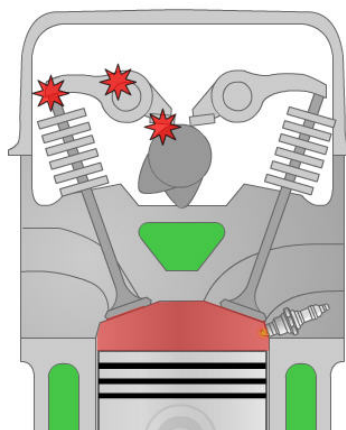

Excessive clearance at any of these points (rocker arm to pivot, cam or valve) can cause noise.

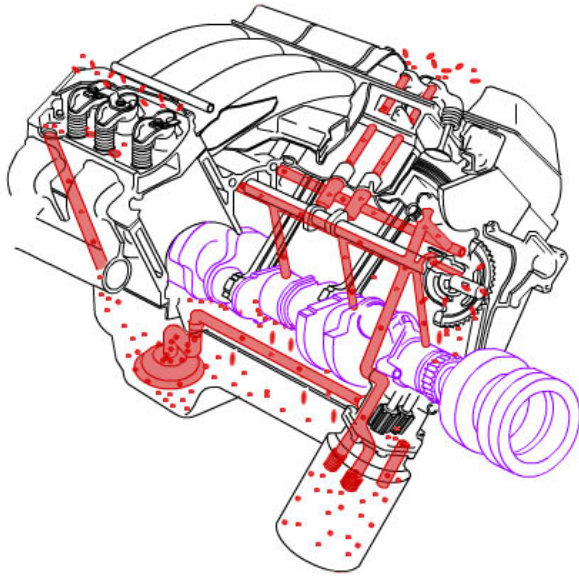

The Lubrication System

All of the moving engine parts that have been discussed here must be lubricated, which makes the engine's lubrication system a critical part of engine operation. Lubricating oil helps carry away heat and reduces friction and wear between moving parts. If a sufficient quantity of oil under pressure is not delivered to vital engine parts such as rod and main bearing journals, the engine would seize within the first few minutes of operation.

A supply of oil is maintained in the **oil sump** at the bottom of the **oil pan**. Submerged in this oil is a **pickup tube**, covered with a **screen**. The pickup tube leads to the **oil pump**, which is driven by the cam or crankshaft. The oil pump draws its supply of engine oil through the pickup tube. From the oil pump, pressurized oil is usually first delivered to the **oil filter**, and then to the **main oil galleries** for distribution to other engine parts. These main galleries feed the crankshaft bearings and then the connecting rod bearings via passages in the crankshaft. Other branches of the main oil galleries feed oil to the camshaft and valvetrain components. After the oil is pumped across the bearing surfaces of all moving parts, it sprays, oozes or drips away. At various points inside the engine, the oil then flows into **drain holes** that collect it and return it to the crankcase.

The oil pump must provide pressure at all engine operating speeds. The faster the oil pump turns, the more oil is pumped, and so a **pressure relief valve** is used to divert excess pressure at high speeds. Also, a **bypass valve** near the oil filter opens in the event of a clogged filter to prevent oil starvation.

As discussed earlier, correct bearing clearance is critical to maintaining oil pressure. All engines lose a certain amount of oil pressure over time as normal wear increases bearing clearances. As these clearances become excessive, oil pressure bleeds off, reducing the flow of pressurized oil to other parts of the engine. This in turn can cause the valve train to become noisy and wear rapidly. Also, when bearing clearances are excessive, the protective film of engine oil that normally prevents actual metal-to-metal contact at the bearing surfaces can no longer be maintained. The engine will begin to knock.

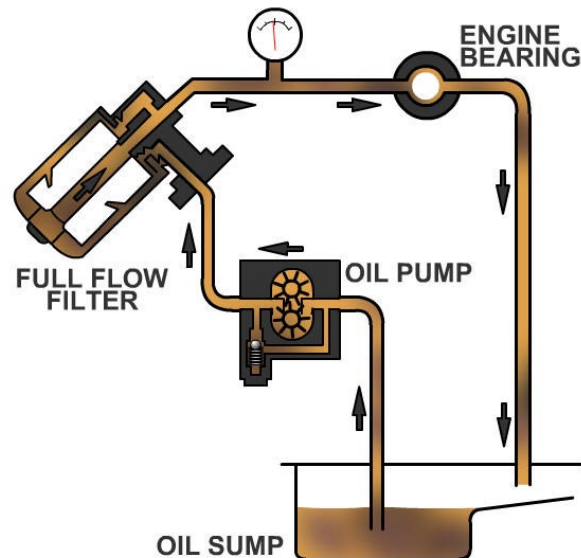

Flow of Oil in the Lubrication System

Diagnosing Excessive Oil Consumption

Most vehicle manufacturers define "excessive oil consumption" as consuming or using a US quart or more of engine oil in 1,000 miles or less of vehicle operation. Lesser rates of oil consumption are considered normal operation in almost every case.

Gaskets and seals are used in every engine to keep engine oil contained inside the engine's lubrication system. Oil consumption almost always occurs as a result of oil leaking out of its normal location after a gasket or seal has failed. Even a relatively small internal or external oil leak can cause the loss of a quart of oil over 1,000 miles of vehicle operation.

Keep in mind that gaskets and seals are designed and engineered to keep the engine oil confined to where it is supposed to be inside the engine. This includes keeping oil out of the combustion chambers and cooling system.

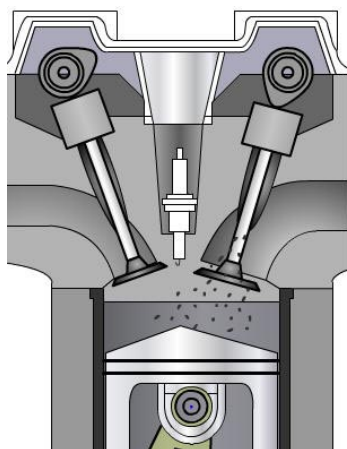

A failed valve seal allows vacuum created during the intake stroke to draw oil past the valve guide into the combustion chamber. This means that oil may leak into the induction system or into the combustion chamber where it is burned during the combustion cycle.

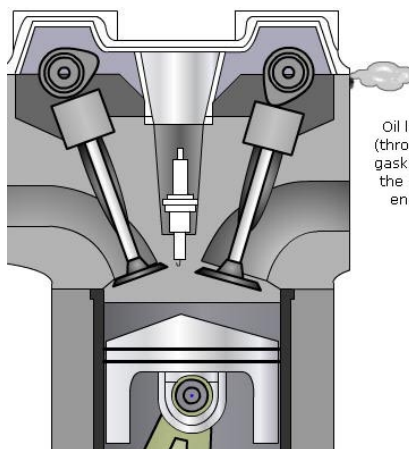

Oil leaks out of the engine (through a failed valve cover gasket in this example) onto the outside surfaces of the engine itself or onto the ground.

Pinpointing External Leaks

External leakage can be detected visually in most cases. Usually external oil leaks from engine gaskets or seals are the easiest to find.

The quantity of the leakage can affect how easily the leak source can be visually detected. Oil leakage can be so slight that the source is not apparent. A leak could also be so massive that one entire section or even the whole engine is covered with oil.

To diagnose large leaks, wash the engine off and run it in short cycles to prevent a flood of oil from covering a large area around the leak a second time.

Small leaks can be diagnosed by washing the leak area off, letting it completely dry, and coating it with a tracing powder to pinpoint an oil seep. Aerosol foot powder (available in any drug store) can be used for this purpose.



Spray the general area of the leak with the foot powder. The resulting white powder film will stick to the engine. Then, run the engine for a half-hour or so in the shop, or drive the vehicle fairly slowly in a parking lot or on a clean, dry road. Keep both vehicle speed and engine RPM slow, as higher engine and vehicle speeds will tend to blow the powder off of areas where it was sprayed.

Using Foot Powder for Visual Leak Detection



- **Always check engine oil and coolant levels prior to running the engine or road testing!**
- **Safety first when road testing – NEVER drive in an unsafe manner when attempting to identify a problem!**
- **Be sure to use approved exhaust ventilation equipment when operating a vehicle in an enclosed area.**

UV Leak Dye

Another way to pinpoint small, difficult-to-trace oil leaks is by adding leak dye to the engine oil. A UV (ultraviolet) light can then be used to find the location of the leak. When viewed under the UV light, the dye glows a bright greenish/yellow that can't be mistaken

for anything else. This may be the best way to pinpoint small leaks that occur only during special circumstances, such as a driving vibrations, road shock, or flexing of components and lines.

When you use the dye, follow the dye kit directions. Larger leaks will show up within a short time once the dye has been added to the engine oil and the engine has been run. For smaller, less obvious leaks, you may have to add the dye to the oil and have the customer return in a few days or even weeks.

To see the leak, put on the UV glasses that come with the UV light. Next, turn on the UV light, shine it on the area you suspect to see leaking and look for a trail of dye from the bottom of the engine upwards. Once the trail is visible under the light, follow it up to the highest point to find the source of the leak.

**UV Leak Dye
for Visual Leak Detection**



Pinpointing Internal Leaks

Internal leakage can be very difficult to detect. In fact, internal leakage will often continue without being detected. Modern engines run at high internal engine temperatures and are also equipped with very efficient catalytic converters. These can mask internal oil leaks by causing any telltale smoke to be burned before it has a chance to make itself visible by coming out of the tailpipe. Oil can leak or be drawn into the induction system via several different paths. Some of the more common causes of internal leakage include:

Intake Manifold Gaskets: Oil can enter the intake manifold at any point where oil is close to a leaking intake manifold gasket. Most (but not all) V-type pushrod engines are designed so that the intake manifold covers the "valley" containing the camshaft, lifters and pushrods. Intake manifold gasket failure on these engines can allow manifold vacuum to suck oil past the leaky gasket into the intake ports where it is delivered with the air/fuel mixture to the cylinder.

Some versions of the GM 60-degree V6 and Ford V6 and V8 engines are designed so that the intake manifold-to-cylinder head gasket is underneath the valve cover. This creates two potential paths for oil to enter the intake runners. A failed intake gasket can cause oil to be drawn from the valvetrain area under the valve cover, and from the area underneath the intake manifold itself.

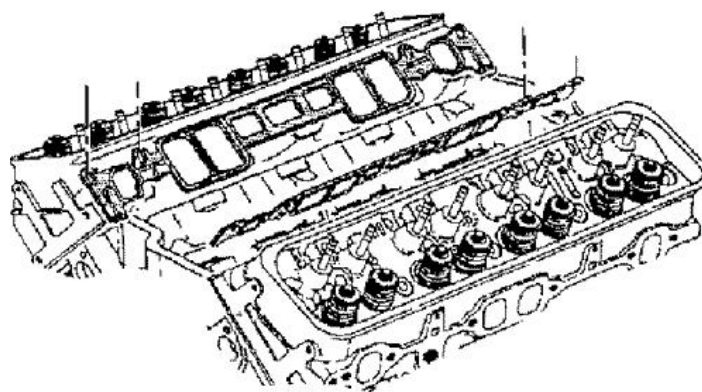
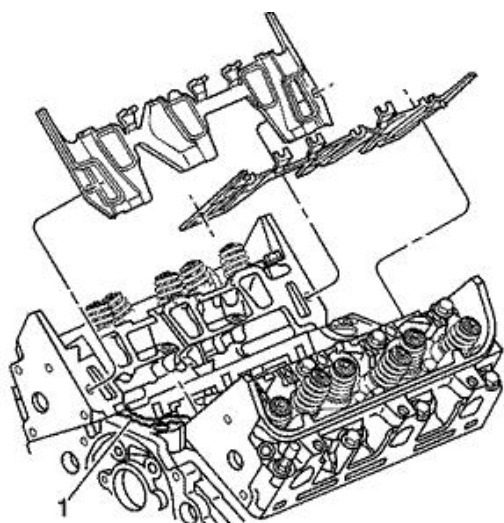

60-degree V6 Intake Manifold Gaskets (left); 90-degree V8 Intake Manifold Gaskets (above)

Propane Enrichment

Pinpointing intake manifold gasket leaks can be difficult. A propane enrichment tool and exhaust gas analyzer can be used to locate them.

To find the leak, remove the PCV valve from the valve cover. Leave the vacuum hose connected to it, and temporarily turn or orient the valve so that it draws in clean air rather than crankcase fumes. Next, connect the Exhaust Gas Analyzer as per the analyzer manufacturer's instructions. Start the engine and allow it to idle. Once the engine is running, use the Propane Enrichment Tool to feed propane into the valve covers, one at a time, via the PCV grommet or oil cap. If there is a manifold gasket leak, the propane will be pulled into the cylinders by manifold vacuum. This in turn will cause the Carbon Monoxide and Hydrocarbon readings on the Exhaust Gas Analyzer to change.



Propane Enrichment Tool



Exhaust Gas Analyzer

Some manifold gasket leaks will be large enough to cause the engine to smooth out or change speed once the propane is applied at idle. If the manifold gasket leak is very small, this test may not be conclusive.

Valve Guides and Seals: The vacuum created inside the cylinder by the intake stroke is applied directly to the intake valve stem. If the valve stems or valve guides are worn, or if the valve stem seals are defective, oil can be drawn into the intake runner at the cylinder intake port.

Worn exhaust valves, guides, or seals can cause oil consumption as well. At a point between the exhaust stroke and the intake stroke, the exhaust valve will still be open though the piston has reached the top of its stroke. At this point, the "venturi effect" of the exhaust gases moving out of the engine can cause a vacuum in the combustion chamber. This vacuum is momentary but can be strong enough to pull oil through a worn exhaust valve guide around the valve stem. Once siphoned past the exhaust valve, the oil will be burned by the hot exhaust gases in the exhaust ports and manifold.

When the engine is shut down, oil drains from the top of the cylinder head back to the crankcase. During this time, oil can leak past worn out or split valve seals and worn valve guides onto the backs of closed valves or into any cylinder where a valve is open.

Pinpointing valve guide and seal leaks can be difficult. One sign of potential valve guide or valve seal leakage would be heavy blue smoke coming from the tailpipe immediately after the vehicle is started. The volume of smoke will slowly taper off as the engine runs. The smoke volume tapers off for two reasons. As the engine warms, the valves and guides expand slightly. This reduces the amount of oil being pulled into the cylinders. Also, as the catalytic converter comes up to "light-off" temperature it begins to consume the oil smoke before it exits the tailpipe. Visible smoke on deceleration is another potential sign, but, again, this may not be seen with a modern engine.

Worn valves, guides, and seals may cause oil residue in the form of carbon to build up on the backs of the valves. Intake valves run cooler and are more susceptible to this. Exhaust valves run hotter and may not have any or as much carbon buildup. This buildup can be seen in some cases using a borescope to view the back of the valve via the intake port.



Carbon Deposits on Intake Valve

Boscopes are used for inspection work where the area to be inspected is inaccessible by other means. They are usually fitted with a magnifying device and a way to illuminate the area being inspected. Port fuel injectors can be removed on engines so equipped to get a glimpse of the back of the valve as well. Another method of inspecting the back of the valve with a borescope is to go in via the spark plug hole and rotate the engine carefully by hand until the intake valve is open.



Flexible Borescope

Valve and guide inspection and measurement, which requires cylinder head disassembly, is often the only way to determine valve and guide wear. Compression and cylinder leakage tests will not pinpoint worn valve guides or leaking valve seals.

Many technicians will replace valve seals on high-mileage engines in response to customer complaints of oil consumption and/or visible smoke out of the tailpipe. This is a short-term repair in many cases. If the valve stems and guides are worn, excessive play between the two surfaces will wear new positive type valve seals out quickly.

Cylinder Bores and Piston Rings:

As discussed earlier in this section, oil can enter the combustion chamber by “blowing by” worn cylinder bores, worn pistons, or worn or broken piston rings. Compression and cylinder leakage tests will provide valuable clues to determine if worn cylinder bores, pistons, or rings are responsible for excessive oil consumption.

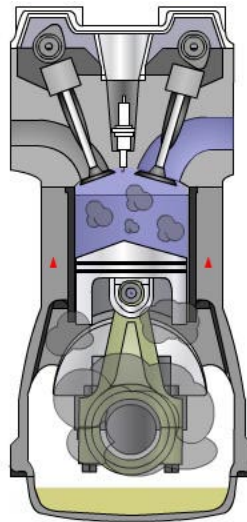

As the piston travels downward on the intake stroke, oil can enter the combustion chamber by “blowing by” worn cylinder bores, worn pistons, or worn or broken piston rings.

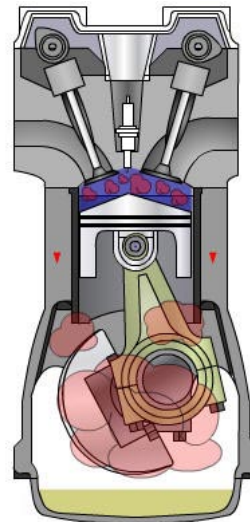

As the piston travels upward on the compression stroke, fuel can enter the crankcase by “blowing by” worn cylinder bores, worn pistons, or worn or broken piston rings.

Suggested Courses of Action

High-mileage engines that consume excessive amounts of oil often have multiple problems. In many cases, diagnosis of high-mileage, oil-burning engines will reveal that the entire engine assembly is worn.

If any part of the engine is repaired in an attempt to reduce oil consumption, the repair could place additional strain on another part of the engine. Therefore, high-mileage engines are best completely reconditioned the first time. Partial reconditioning may actually increase oil consumption.

Diagnosing Oil Pressure Problems

Along with oil consumption problems, the next most common lubrication system problems relate to engine oil pressure, flow, and volume.

The three most common oil pressure problems are as follows:

- Low oil pressure, which can be indicated by low oil pressure gauge readings (if the vehicle has an oil pressure gauge), or an oil pressure indicator light coming on while the engine is running. Abnormal engine noises (knocks, rattles, ticks or other mechanical noise) may also be noticeable.
- High oil pressure, which can be indicated by high or excessive oil pressure gauge readings (if the vehicle has an oil pressure gauge), or an obviously swollen oil filter housing.
- A malfunctioning oil pressure indicator light or gauge circuit, which can indicate that there is an oil pressure problem when the system is actually functioning normally.

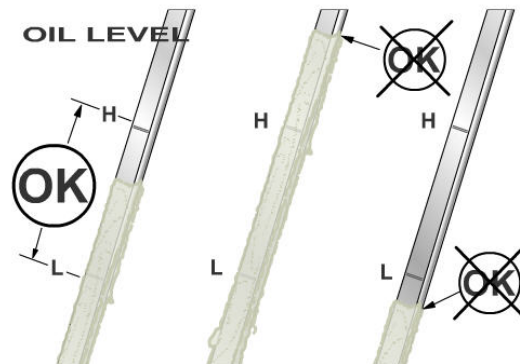

As simple as it sounds, checking the engine oil level and condition should be where diagnosis begins. The dipstick should read full when checked, and the oil should be clean and of the correct viscosity as specified by the engine manufacturer.

Change Oil / Test Pressure

If there is any doubt whatsoever about the condition of the engine oil or oil filter, change it before going any further in your diagnosis. Even if further diagnosis reveals major mechanical problems, four or five quarts of the correct viscosity oil and a clean, correct oil filter are a very cheap way of eliminating potential variables during the diagnostic process.

Be sure to observe the condition of the engine oil while it is being checked or drained during the oil change. Oil that appears “thin” or “watery” and that has a strong fuel odor is a sign of fuel entering the crankcase. A ruptured fuel pump diaphragm on a carbureted vehicle is a common cause for this. Any condition that can cause excessively rich fuel mixtures could potentially cause fuel contamination of the engine oil as well. The cause of the contamination needs to be diagnosed and repaired.

Oil that appears “milky” is a sign of coolant entering the crankcase. If this is found, the cause of the coolant contamination needs to be diagnosed and repaired as well.

If a low or abnormally high oil pressure condition is still indicated after the oil and filter have been changed, test the oil pressure with a test gauge as per the vehicle manufacturer’s published procedure, and compare the test readings with manufacturer’s published specifications.

Measuring oil pressure with a test gauge after changing the oil and filter will quickly provide diagnostic direction. If the oil pressure test results are within manufacturer’s specifications using a test gauge but the vehicle’s oil pressure gauge or light reads abnormally, follow the vehicle manufacturer’s published procedure for testing the oil pressure light or gauge sending unit and circuit.

Abnormally high oil pressure as measured by a test gauge after changing to the correct oil and filter is generally caused by a stuck oil pressure relief valve.

- **Vehicle manufacturer’s published service information should be consulted for diagnosis and repair of a high oil pressure condition.**

Abnormally low oil pressure as measured by a test gauge after changing to the correct oil and filter indicates an engine mechanical problem. If the engine is knocking or mechanically noisy, engine damage has probably already occurred.

When oil pressure and flow are restricted inside an engine, the resulting engine damage almost always happens before the gauge or warning light indicates a problem. In many cases, the circuit controlling the oil pressure warning lamp is designed not to turn the lamp on until the actual oil pressure is less than 4-5 PSI (27.6-34.5 kPa).

Further diagnosis of low oil pressure and mechanical noise usually requires oil pan removal and a thorough inspection of the oil pump, oil pump pickup, and engine bearings.



Oil Warning Lamp and Gauge

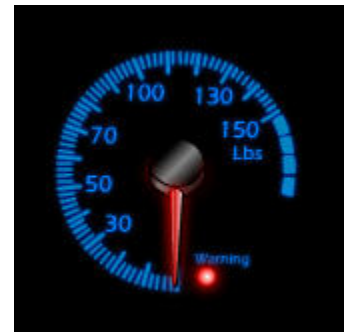

Suggested Courses of Action

High-mileage engines with low oil pressure and mechanical noise often have multiple problems. In many cases further diagnosis will reveal that the entire engine assembly is worn.

Repair attempts made upon worn engines can sometimes compound problems. Installing a new oil pump in a worn engine may increase the oil pressure slightly for a short time, but it does nothing to reverse the wear that has already occurred. Therefore, high-mileage engines are best replaced or completely reconditioned the first time.

Inspection, Removal, and Installation of Engine Covers

Repairing external oil leaks or diagnosis requiring a deeper visual inspection will sometimes mean removing engine covers. Manufacturer’s specific service procedures should always be followed when removing and replacing valve covers, engine timing covers, oil pans and other engine components. A generic overview of this removal and installation process is as follows.

Remove the engine components that are blocking access to the engine cover. Components and their associated brackets such as air conditioning compressors, alternators/generators or power steering pumps must sometimes be partially or completely removed for access.

- **Manufacturer’s specific service procedures detailing component and fastener removal or installation sequence and fastener torque should be followed to the letter.**

A/C Compressor Bracket

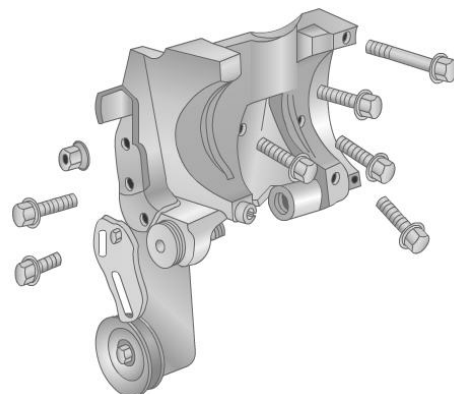

Unfasten the cover and lift it off. If the cover does not come off easily during the removal process, tap it with a rubber hammer to loosen it.

Avoid prying against engine covers. Engine covers are easily dented, distorted or cracked by prying on or against them. Never insert a screwdriver, chisel, or prybar under a stuck cover by way of the cover's gasket sealing surface. This can damage the sealing surface and cause more leakage.

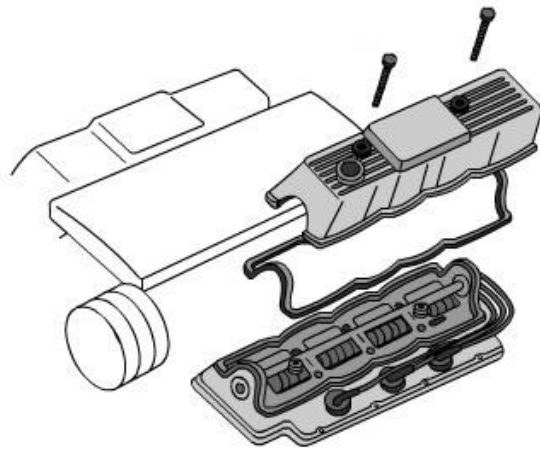

Valve Cover Removal

Inspect the cover for damage and warpage. Gasket mating surfaces in particular need to be smooth and straight. Be sure to also thoroughly inspect both the cover itself and the gasket surface on the part the cover attaches to. Gasket mating surfaces of engine covers should be checked for straightness visually. A straight edge can be used if there is any question as to whether or not a particular gasket sealing surface is straight and true.

Stamped metal covers may become “dimpled” or distorted around the fastener holes. This usually occurs as a result of over tightening the fasteners either during initial installation or in an attempt to stop a leak. These distorted areas should be carefully straightened. If they cannot be straightened, the cover in question should be replaced.

Remove the old gasket, seal, or sealer. Pull as much of the gasket or sealer as you can get off by hand. Some engines and engine covers use silicone gaskets that are meant to be reused. Late model small-block Chevrolet V8 engines with center-bolt valve covers are an example. If there is any question or doubt about the condition or integrity of a reusable gasket, replace it.

Clean the cover thoroughly with a parts washer or soap and water. Be sure to wash off as much grease, oil, debris, and gasket residue as possible. This is also the time to clean up any hardware, brackets, and fasteners that were removed. Don't forget to clean out fastener holes and threads.

Use a gasket scraper to remove debris and gasket residue from both of the gasket mating surfaces. Cleaning gasket surfaces with surface conditioning disks is NOT recommended by vehicle manufacturers. Surface conditioning discs shed Aluminum Oxide and metal particles as they are used. This contamination, which can be in the form of particles too small to be caught by the oil filter, can lead to premature engine bearing failure. In some cases, this failure occurs in as little as 1,000 miles (2,200 km) after the repair has been made.

Use a razor blade or a small scraper to scrape the remaining gasket material off of the mating surfaces. It is very important that all old gasket material is removed. A chemical gasket remover can be used to soften up tough material. Try not to get the scraped-off gasket residue into oil or coolant passages. These can sometimes be shielded or blocked with clean shop towels.

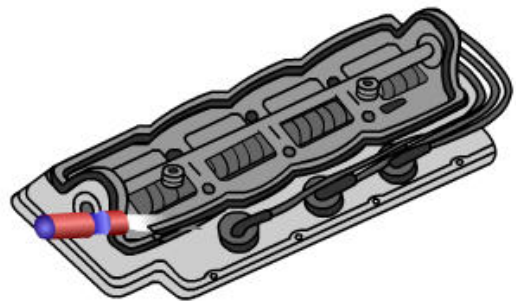

Scraping Valve Cover Gasket

- **Be especially careful not to gouge or scratch gasket mating surfaces while removing gaskets.**

On aluminum gasket mating surfaces, try using a plastic or wood gasket scraper first. This minimizes the risk of unintentional scratches or gouges. A metal scraper can be carefully applied to tough spots.

Install the new gasket, seal, or sealer as specified in manufacturer's service information. Don't use sealers, grease, or other chemicals or substances on the gasket or mating surfaces unless manufacturer's service procedures specify it.

Install the cover and refasten it per specifications. Use care not to undertorque, overtorque, or cross-thread the fasteners used.

Install the engine components that were removed to access the engine cover. As mentioned during the removal process, manufacturer's specific published service procedures detailing fastener removal or installation sequence and fastener torque should be followed to the letter.

Once the engine is completely reassembled, double-check engine oil and coolant levels, and then start and run the engine long enough to verify that there are no leaks in the repaired area.

- **Be sure to use approved exhaust ventilation equipment when operating a vehicle in an enclosed area.**

Diagnostic Testing

Certain engine problems will require more in-depth testing of the engine's overall mechanical condition beyond the preliminary testing steps discussed previously. Some of these more in-depth tests include those for **engine vacuum**, **cylinder power balance**, **cylinder compression** and **cylinder leakage**.

Manifold Vacuum and Testing

Vacuum / Pressure

In reference to vacuum and pressure, keep in mind that a vacuum still has a certain amount of pressure. It is simply lower than atmospheric pressure. Normal atmospheric pressure at sea level is 14.7 pounds per square inch (psi) (49.8 kPa), but most standard pressure gauges, such as a tire gauge, assign atmospheric pressure a value of "0." Some pressure specs are actually expressed in "psig," indicating "pounds per square inch – gauge," to distinguish them from absolute pressure.

The amount of vacuum formed in the manifold depends on several factors. First, the cylinders must be sealed. If a cylinder has low compression or high leakage, it may not produce sufficient vacuum to draw in the air-fuel mixture. Second, the manifold must be sealed, or vacuum will be lower than normal. Gaskets, vacuum hoses, vacuum operated systems, and accessories that operate on vacuum may leak, causing a lower level of manifold vacuum.

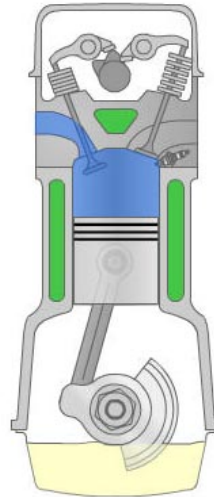

As the intake valve opens and the piston travels down during the intake stroke, air pressure in the area above the piston decreases. Air pressure also decreases during this time in the entire length of the intake passage from the intake valve itself up to the throttle plate in the carburetor or throttle body. Any pressure that is lower than atmospheric pressure will be defined in this discussion as a vacuum.

The strength of the vacuum created affects the distribution of air and fuel to the cylinders. Higher vacuum means better distribution. An engine's ability to form and hold a vacuum is directly related to its ability to form and hold compression. When an engine loses the ability to create vacuum, performance suffers.

When the throttle plate is closed at idle, the vacuum in the manifold is greatest. When the throttle plate is open and the manifold is exposed to atmospheric pressure, vacuum is lower.

Using a **vacuum gauge** to check manifold vacuum is a quick and easy way to test an engine. A manifold vacuum measurement is a good indicator of the engine's ability to run efficiently. A properly tuned engine in good mechanical condition should produce a steady reading of between 15 and 22 inches of mercury (inches Hg) (between 50.8 and 74.5 kPa). This should be measured at idle, in drive (vehicles equipped with an automatic transmission) and at normal operating temperature.





Vacuum measurements change with load, so if accessories are operated while monitoring vacuum, the readings will change. Vacuum readings will also vary between engines. One reason for this variance is differences in compression ratios. If an engine has higher compression, it will have 1 to 2 inches Hg (3.39 to 6.77 kPa) higher vacuum. Altitude also affects vacuum. For every 1,000 feet above sea level, vacuum will be lower by 1 inch Hg or 3.39 kPa. Some engines that use a high lift camshaft or have considerable valve overlap will produce a slightly lower, erratic needle reading on a vacuum gauge.

Some areas that can be diagnosed using vacuum readings include:

- Engine components (i.e., valves, valve guides and springs, piston rings)
- Manifold leaks
- Valve timing
- Restricted exhaust system.

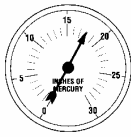
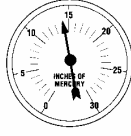
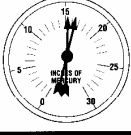
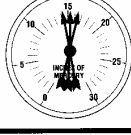
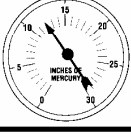
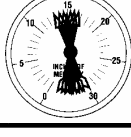
In addition, low or insufficient manifold vacuum readings can significantly affect the performance of computer-controlled engine management systems. This is because these systems typically use either a **manifold absolute pressure (MAP) sensor** or a **mass airflow (MAF) sensor** to influence spark timing and fuel control.

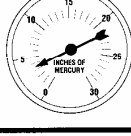
- **Accurately diagnosing problems with a vacuum gauge can be difficult. There is no substitute for practice and experience. Consider vacuum gauge readings to be just one piece of diagnostic information when assessing engine mechanical performance and integrity. Study and compare vacuum gauge readings to diagnostic charts.**

	Readings	Possible Cause
	1. Average, steady readings between 15–22 inches Hg (normal readings for a 60° V6 engine may be lower, i.e., 12–16 inches Hg)	1. Normal
	2. Low but steady, between 12 and 15 inches Hg	2. Leakage around piston rings, late ignition timing, or late valve timing
	3. Needle fluctuates or drops between 1 and 2 inches Hg at idle	3. Burned or leaking valve or spark plug in one of the cylinders is not firing
	4. Irregular needle drop between 1 and 2 inches Hg	4. Sticking valve, intermittent spark plug misfire, or rich or lean air/fuel mixture
	5. Normal at idle speed, but excessive vibrations at higher rpm	5. Weak valve springs; valves sticking in guides
	6. Excessive vibrations at idle speed, but steadies at higher rpm	6. Worn valve guides
	7. Excessive vibration at all rpm	7. Leaky head gasket
	8. Needle oscillates slowly, or drifts, between 3 and 9 inches Hg lower than normal	8. Intake system leak
	9. Normal at idle speed, but drops to near zero and rises to lower than normal	9. Restriction in exhaust system

Manifold Vacuum Readings and Possible Indications

Power Balance Testing

Power Balance Testing is another method of determining general engine condition. This test measures how much the engine speed changes when individual cylinders are disabled one-at-a-time. If each cylinder is contributing an equal amount of power to the engine, disabling any cylinder should change the engine speed equally.

This test is usually performed using a **scan tool** or **engine analyzer** to turn off either spark or fuel injection to a particular cylinder for two to three seconds.

For example, let's look at a four-cylinder engine. Disabling cylinder 1 while the engine is running at a slow cruise speed (1200 RPM) should make the engine speed decrease by about 15% to about 1000 RPM. Enabling cylinder 1 and then disabling cylinder 2 should also make the engine slow down by the same amount. If disabling a cylinder only causes a 3% engine speed reduction, that cylinder is weak because it is not producing as much power as the others. The difference in the amount of engine speed change between any two cylinders should not exceed 5%.

Engine Analyzer (left), Scan Tool (right)



Six and eight-cylinder engines will show smaller engine speed decreases when one cylinder is disabled. Disabling one cylinder on an eight-cylinder engine still leaves seven power-producing cylinders, so the overall decrease in engine speed will naturally be smaller.

This test will tell you if there are one or more cylinders that have weaker power output, but it will not tell you why a particular cylinder is weak. The cause could be related to fuel delivery, ignition, a vacuum leak, or lack of compression. These items should be tested and verified for any cylinder that a power balance test indicates as weak.

When performing a power balance test, refer to both the vehicle manufacturer's published procedures and the instructions provided with your engine analyzer or scan tool. Computer-controlled engine management systems will need to have the oxygen sensor, idle speed control, and EGR temporarily disabled in some cases. This is done to keep the engine controller from changing engine speed, fuel mixture, or ignition timing in response to cylinders being disabled.

Compression Testing

We have noted that the engine cylinders must produce and hold good compression pressure for proper combustion to take place. Cylinder compression pressure can be checked using a compression tester, an inexpensive and simple tool.

There are two types of compression tests:

- A **cranking compression test**, which can help identify leaking piston rings, leaking valves, or a blown head gasket.
- A **running compression test**, which determines the engine's "breathing ability" and volumetric efficiency. Volumetric efficiency is the measure of the quantity of air brought into the cylinder during engine operation. More correctly, volumetric efficiency is a ratio (or percentage) of the quantity of fuel and air that actually enters the cylinder during induction to the actual capacity of the cylinder under static conditions.



Compression Tester

Cranking Compression Test

To run a cranking compression test, all spark plugs are removed, the ignition and fuel injection systems are disabled, and the end of the tester is threaded into a spark plug hole. The throttle is blocked open and the engine is then cranked through at least four compression strokes. The result is recorded and the procedure is repeated on each cylinder.

On gasoline engines, compression is normally 125 to 175 psi (862 to 1207 kPa), but the main concern is that the pressures are fairly uniform in all cylinders. Pressure should not vary more than about 15% from the highest to lowest, or around 15 psi to 20 psi (103 to 138 kPa). Low compression in one or two cylinders will cause a loss of power and poor running, especially at idle. A cylinder with very little or no compression will cause a "dead miss" on that cylinder at all speeds. An engine with low compression on all cylinders may lack power but run smoothly.

Here are some guidelines for interpreting cranking compression test results:

- Low compression on all cylinders can be caused by a worn or jumped timing chain or belt, or worn compression rings or cylinders. The timing chain/belt can be tested using other means.
- Low compression on two cylinders next to each other can be caused by a blown head gasket.
- Low compression with no apparent pattern among the cylinders may be caused by valve train problems such as valves being out of adjustment (not closing), broken valves or valve springs, and burned valves or seats. It can also be caused by engine damage such as a hole in a piston or cylinder wall. Broken piston rings or a cracked block or head can also cause low compression.

To determine if the problem is worn piston rings or cylinder walls, a **wet compression** test is performed. A maximum of one tablespoonful of 30W motor oil is squirted into the spark plug hole of the low cylinder and the test is run again. The oil provides a temporary seal for worn rings. If compression rises to normal, worn rings and/or cylinder walls are indicated. Note that if too much oil is used, the pressure will go up even if the rings are good. The oil takes up some of the combustion chamber volume, which increases compression.

Running Compression Test

A running compression test, as its name implies, is performed on one cylinder with the engine running. To perform this test, run the engine until it is at normal operating temperature. Remove the spark plug from the cylinder you're testing and connect a spark tester to the plug wire. Install the compression tester into the spark plug hole, and then start the engine and allow it to idle.

- **Be sure to use approved exhaust ventilation equipment when operating a vehicle in an enclosed area.**

Compression tester readings are observed and recorded at idle, at 1500 RPM, and while very quickly snapping the throttle wide open. The compression gauge pressure is released between each of these readings.

- Running compression at idle should measure 100 (+/-20) psi (690 +/- 138 kPa).
- Running compression at 1500 rpm should measure 60 (+/-20) psi (413 +/- 138 kPa).
- Running compression when snapping the throttle open and closed should measure within 80% of wide open throttle cranking compression.

Measurements should be compared from cylinder-to-cylinder.

How It Works

When performing a running compression test, measurement readings will be lower overall than cranking compression test readings.

There are two reasons for this. While the engine is running at idle, the throttle plate(s) in the carburetor base or throttle body are closed almost completely. This restricts the quantity of air that can enter each cylinder. Also, at idle the engine runs faster than when it is being cranked over by the starter. This means that less air enters because there is less time between piston strokes for air to fill the cylinder.

Quickly snapping the throttle open temporarily removes the airflow restriction, which in turn causes running compression measurements to increase. Pay particular attention to the snap-throttle measurements, as they will provide an indicator of how well each individual cylinder is "breathing."

Interpreting the Results

If the snap-throttle measurement is **less** than 80% of the cranking compression reading for an individual cylinder, it means that less air is entering that cylinder on the intake stroke. Possible causes could include intake-side valvetrain problems or a heavily-carboned intake valve. If the vehicle being tested is equipped with a variable-length intake manifold system (a Ford Duratec 3.0 V6, for example) then that system should be checked for proper airflow and operation as well. Low snap-throttle measurements on all cylinders indicate an intake problem that is common to all cylinders. Possible causes could include a camshaft timing problem or an intake restriction in an area that feeds all cylinders.

If the snap-throttle measurement is **significantly greater** than 80% of the cranking compression reading for an individual cylinder, it means that less air is leaving that cylinder on the exhaust stroke. Possible causes could include exhaust-side valvetrain problems. High snap-throttle measurements on all cylinders indicate an exhaust problem that is common to all cylinders. Possible causes could include a camshaft timing problem, a clogged catalytic converter or an exhaust system restriction.

Cylinder Leakage Testing

Cylinder Leakage testing is performed to determine the amount of compression loss in a cylinder and pinpoint the source of compression leakage. Several tool manufacturers make cylinder leakage testers, or one may be easily fabricated from an adjustable air pressure regulator and some pipe fittings.

Cylinder leakage testing should be done with the engine at operating temperature to produce the most accurate results. Remove the spark plug in the cylinder to be tested, bring the piston to TDC, and then introduce regulated compressed air into the cylinder via the spark plug hole.

Follow the leakage tester manufacturer's directions for testing specifics. For a street engine, generally 10% or less leakage is acceptable, and 20% leakage is not unheard of.

Leakage location can be found by listening for the sound of air escaping while the cylinder is pressurized. There are five major leak paths where cylinder pressure can escape:

- Past the piston rings
- Past the intake valve
- Past the exhaust valve
- Past the head gasket
- Through a crack in the cylinder head or engine block



Cylinder Leakage Tester

If you can hear air pressure hissing from the valve cover breather hole, the PCV valve grommet or the dipstick tube, then the air pressure is escaping past the rings. If you prop open the throttle blades and hear that same hissing sound, then the pressure is leaking past the intake valve. If the air is escaping past the exhaust valve, you will probably be able to hear the hissing sound at the tailpipe. Air bubbles in the radiator while the cylinder is under pressure indicate a blown head gasket, cracked cylinder head, or cracked engine block. A blown head gasket can sometimes also be found by removing an adjacent spark plug and listening for the sound of air escaping from the next cylinder over.

Engine Removal and Installation

There are so many different vehicle designs, engine and drivetrain configurations, and other variables that it would be impossible to come up with a valid, generic set of engine removal and installation instructions.

Some engines are removed by lifting them from the vehicle, and some are removed by raising the vehicle on a lift or hoist and lowering the engine out. Some engines are removed with the transmission or transaxle still attached, and some will require separation from the transmission or transaxle before removal. Some vehicle designs may require that the engine be partially disassembled before removal.

- ***When removing or reinstalling an engine, follow manufacturer's specific published service information and instructions for the vehicle that you're working on.***
- ***Also follow standard safety guidelines and procedures when using engine cranes and stands, lifting equipment and safety stands.***
- ***Manufacturer's specific published service procedures detailing component and fastener removal or installation sequence and fastener torque should be followed to the letter.***

Be sure to drain coolant and other necessary fluids as completely as possible before engine removal to avoid spills.

Unit 3 – Cylinder Head and Valvetrain Diagnosis and Repair

Unit Objective:

After completion of this unit, students should be able to identify cylinder head and valvetrain components and functions and perform diagnostic and repair procedures on those components.

Specific Objectives:

- Identify cylinder head and valvetrain associated terms and definitions
- Understand and be able to explain:
 - the construction and function of the cylinder head and valvetrain
 - valve seal replacement procedures on an assembled engine
 - the procedures for cylinder head removal, disassembly, and inspection
 - the procedures for cylinder head installation
- Identify valve train diagnosis and repair associated terms and definitions
- Understand and be able to explain the procedures for:
 - inspecting valve train components
 - identifying and interpreting engine concerns
 - checking and adjusting valve lash
 - inspecting, adjusting, and replacing camshaft drive components
 - timing the camshaft and crankshaft

Cylinder Head Function and Construction

As stated earlier in this course, the cylinder head's main job is to contain the rapid increases in combustion chamber temperature and pressure that occur when the air/fuel mixture ignites. In addition, the overhead valve cylinder head provides the mounting point for the parts that actuate the valves, as well as for the intake and exhaust manifolds.

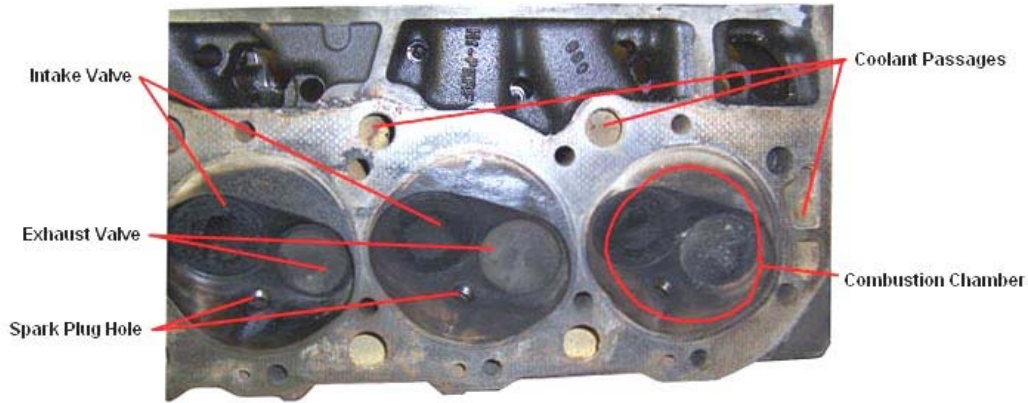

Underside of Cylinder Head

Valves, Guides & Seats

Intake and exhaust **valves** open and close their respective ports. Small holes called **valve guides** are machined into the ports to position the valves. Valve guides are the bearings upon which the valves move.

Some engine designs use separate, replaceable valve guides. These are most often press fitted into the cylinder head. Others use nothing more than a hole of the correct diameter machined into the head to guide the valve.

The valves close against precision-machined areas or inserts in the combustion chamber ends of the ports called valve seats. These are shown here in cutaway view. As with the guides, some engines use press fitted replaceable valve seats while others have the seat machined directly into the cylinder head.

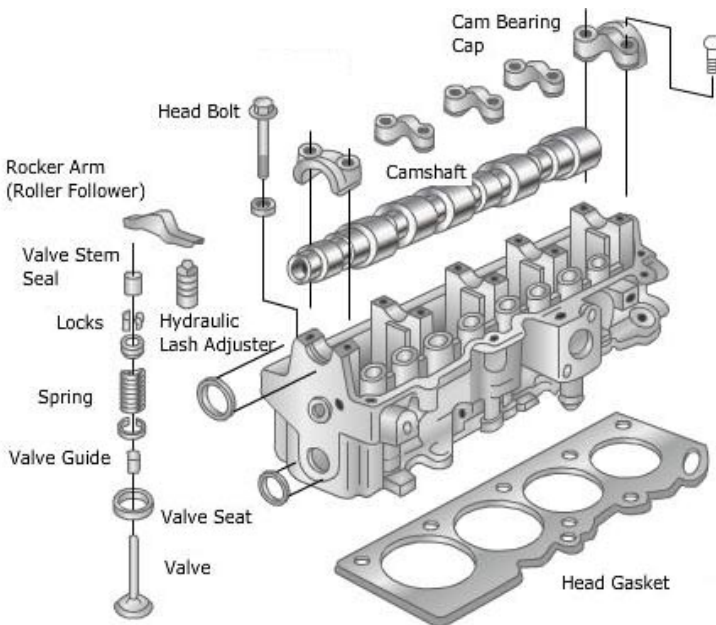
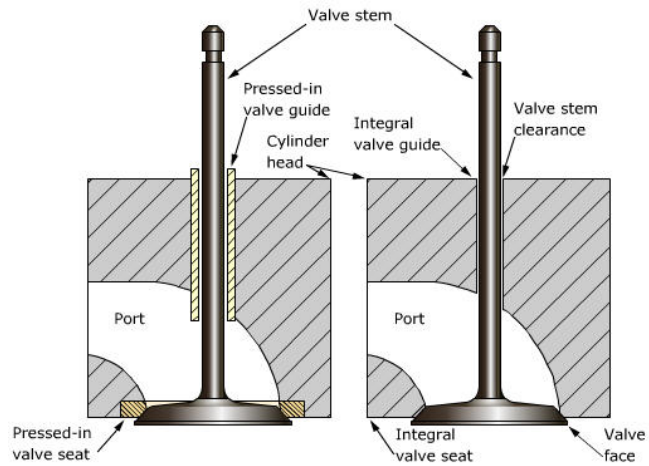

Valvetrain Construction

Single Overhead Camshaft Engine

The **valvetrain** consists of the **valves**, **camshaft**, and other associated parts.

Pushrod Engine

Engines with the camshaft located in the block are called **pushrod engines**, because long pushrods are used to transmit the camshaft's movement up to the **rocker arms**, which rock to open the valves. On these engines, the cam acts on a valve lifter, which in turn acts on a pushrod to move the rocker arm and open the valve. Different engine designs may use different valvetrain designs, some of which may not have all of the components previously listed.

Each valve must open and close at exactly the right time relative to the position of each piston. This is accomplished through the camshaft and cam drive.

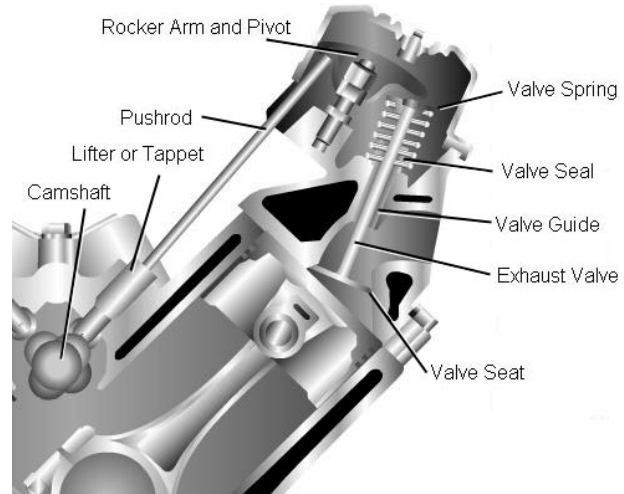
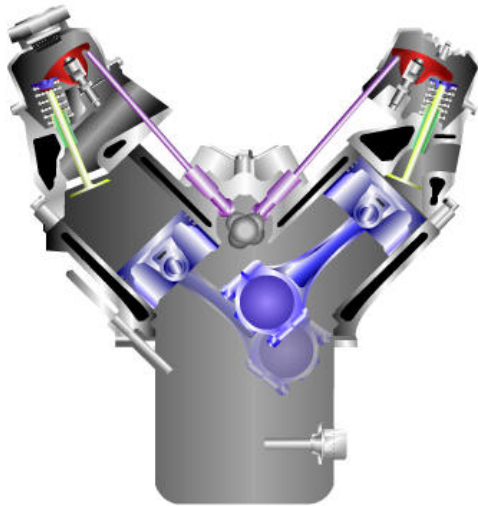

Pushrod Engine

Valve and Spring Retention

Valve Springs are used to close each valve tightly against its seat as the closing side of the cam lobe passes the valve's actuating mechanism. These valve springs are held in place by a **spring retainer**. Two **valve keepers** are used to "lock" the valve stem to the spring retainer as shown here.

The **O-ring** and **Valve Seal** shown in the graphic are used to prevent engine oil from getting into the combustion chambers via the valve guide. The O-ring keeps oil that collects on top of the **spring retainer** from running down the valve stem. The seal shown on top of the valve guide serves a similar purpose.

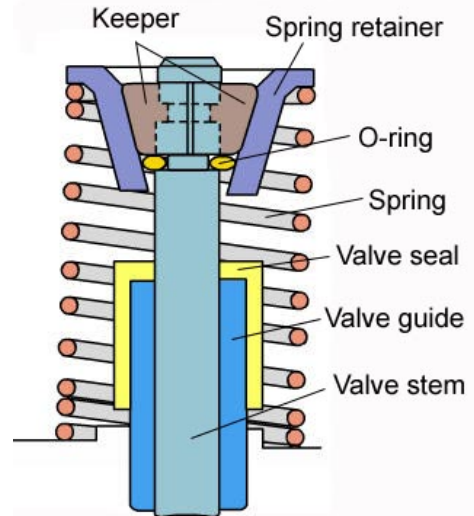

Valve Spring Compressor

To remove the valve spring, or to remove the valve from the cylinder head with the cylinder head off of the engine, a tool called a **valve spring compressor** is used. There are as many different designs of valve spring compressors as there are valvetrain designs, but they generally fall into one of two categories:



The valve spring compressor at right can be used without removing the cylinder head. These are designed for replacing valve springs and/or valve seals with the cylinder head on the car. Compressed air is fed into the cylinder before the spring is removed to keep the valve from falling into the cylinder.

The valve spring compressor at left requires removing the cylinder head. If a valve must be replaced for any reason, the cylinder head must first be removed from the engine block.



Cylinder Head Diagnosis and Repair

On-Car Valve Seal Replacement

As mentioned earlier in this course, many technicians will replace valve seals on high-mileage engines in response to customer complaints of oil consumption and/or visible smoke out of the tailpipe. This is a short-term repair in many cases. Replacing the valve seals does not recondition the cylinder head, and may not solve the oil consumption problem long-term.

- **Manufacturer's specific published service procedures detailing component and fastener removal or installation sequence and fastener torque should be followed to the letter.**

A generic overview of the valve seal replacement process is as follows. Note the key points in bold.

1. Disconnect the negative battery cable.
2. Remove the engine accessories necessary for valve cover removal.
3. Remove the valve cover(s).
4. Remove the valve train components (e.g., rocker arms, camshafts) necessary to gain access to the valve springs.
5. Remove the spark plugs.
6. Insert an air hose adapter into the spark plug opening for the cylinder being serviced.
7. Connect the shop air hose to the adapter and pressurize the cylinder.
8. Use a valve spring compressor to compress the valve spring.
There are as many different designs of valve spring compressors as there are valvetrain designs. Be sure to use the right compressor for the engine you're working on to minimize the possibility of injury or damage.
9. Remove the valve locks, retainers, and spring (See image).
A magnet will be handy here to remove and capture the valve locks. Be careful not to drop them once they have been removed.
10. Remove the old valve stem seal.
11. Inspect the valve locks, valve lock grooves, and the valve stem and tip for signs of wear or damage.
12. Inspect the valve springs for squareness and signs of wear or damage. Measure their free height. To do this, stand all of the springs on a flat surface next to each other. They should stand the same height and should stand squarely. If there is any discrepancy in their height or if any of the springs do not stand squarely, replace all of the springs.
The tension of each valve spring can be tested using a special gauge. Extensive testing of valve springs is generally not cost effective. In most cases, it is cheaper to replace questionable valve springs than it is to test them, particularly in a high-mileage engine.
13. Inspect the top of the valve guide for signs of wear or damage.
14. Install a new valve seal.
Use caution to not nick, cut, chip, or otherwise damage the new valve seal during installation.
15. Reinstall the valve spring, retainer, and locks.
Once the valve spring, retainer and locks have been reinstalled, use a brass or plastic-faced non-marring hammer to LIGHTLY tap the tip of the valve stem BEFORE releasing air pressure from the cylinder. Tap ONLY THE TIP of the valve stem, NOT the valve spring retainer. Tap lightly, but hard enough to move the valve off of its seat. You should hear a quick "pop" when the valve has moved caused by air pressure momentarily escaping the cylinder. This is done to make sure that the valve locks are properly installed and seated. Incorrectly secured or damaged valve locks will cause major engine damage when the affected valve falls into the cylinder and collides with the moving piston while the engine is running!



16. Repeat these steps for each valve assembly.
17. Reinstall the valve train components and valve cover(s).
18. Reinstall the spark plugs and wires.
19. Reinstall the engine accessories and connect the negative battery cable.
20. Connect the exhaust ventilation equipment.
Be sure to use approved exhaust ventilation equipment when operating a vehicle in an enclosed area.
21. Start the engine and check operation.
22. Shut off the engine. Disconnect the exhaust ventilation equipment.
Again, this is a generic overview of the valve seal replacement process. Manufacturer's specific published service procedures should be followed for the vehicle that you're working on.

Cylinder Head Removal and Disassembly

As with engine removal, there are so many different vehicle designs, engine and drivetrain configurations, and other variables that it would be impossible to come up with a valid, generic set of cylinder head removal instructions. Some vehicles may require that the engine assembly be removed from the vehicle before cylinder head removal because of space limitations.

- **When removing or reinstalling a cylinder head, follow manufacturer's specific published service procedures and instructions for the vehicle that you're working on.**
- **Also follow standard safety guidelines and procedures when using engine cranes and stands, lifting equipment and safety stands.**
- **Manufacturer's specific service procedures detailing component and fastener removal or installation sequence and fastener torque should be followed to the letter.**

Be sure to drain coolant and other necessary fluids as completely as possible prior to cylinder head removal to avoid spills.

If the head is to be resurfaced or reconditioned, it should be partially disassembled once it has been removed from the engine. Bolt-on parts, like the intake and exhaust manifolds, thermostat housing, rocker shaft or camshaft, spark plugs, glow plugs, fuel injectors and the like should be removed at this time if they were not removed while pulling the head off.

- **When removing or reinstalling these parts, follow manufacturer's specific published service information and instructions for the vehicle that you're working on.**
- **Manufacturer's specific service procedures detailing component and fastener removal or installation sequence and fastener torque should be followed to the letter.**

Do not remove the valves and springs at this time. This will be done during the inspection process. If you break a bolt or strip threads on the cylinder head where bolt-on parts attach during disassembly, make note of this. Don't try to extract a broken bolt or perform a thread repair on the cylinder head until after the head has been inspected thoroughly. There's no sense in fixing a cylinder head that an inspection may show needs replacement instead of reconditioning.

Once the cylinder head is off and the external bolt-on parts have been removed, the gasket sealing surfaces must be thoroughly cleaned. Be sure to clean all gasket surfaces, especially the head gasket surface and the manifold surfaces. Any gasket material left on the head surface will cause a leak when the engine is reassembled. The head gasket surface on the cylinder block deck should be cleaned as well.

- **Use a gasket scraper to remove debris and gasket residue from gasket mating surfaces as previously discussed. Cleaning gasket surfaces with surface conditioning disks is NOT recommended by vehicle manufacturers.**

Cylinder Head Inspection

Knowing the specific customer complaint (as discussed earlier) can help you find what you're looking for when inspecting the cylinder head.

For example, cooling system concerns, like overheating and loss of engine coolant, can in many cases be traced to a warped or cracked cylinder head. Oil consumption complaints can sometimes be traced to worn valves and guides. Misfire and power loss complaints are sometimes caused by burned valves that cannot keep the pressure of combustion confined to the inside of the cylinder.

In addition, you may find that in some cases that replacing cracked, worn, or high-mileage cylinder heads with new or reconditioned heads makes the most economic sense for the vehicle owner.

Warpage Check

Check the head gasket surface for warpage using a **precision straightedge** and a set of thin **feeler gauges**. Check the head gasket surface lengthwise and crosswise in several places.

As a general guideline, warpage lengthwise should not measure more than .003 in. (0.076 mm) for a three cylinder (V6) head, .004 in. (0.102 mm) for a four cylinder or V8 head, or .006 in. (0.152 mm) for a straight six head. When measuring side-to-side, the maximum allowable limit for warpage for any head is .002 in. (.05 mm)

- **Manufacturer's specific specifications for warpage should be followed to the letter. The figures given here are general guidelines.**

If a cylinder head is warped, it should be straightened before any other machine work is done. This is typically a job that most shops will sublet out to an automotive machine shop.

Some heads can be milled (shaved down) to make the gasket sealing surfaces flat and true again. Overhead cam cylinder heads are sometimes straightened by bolting the head down over shims to a straightening fixture. The head and fixture are then heated in an oven to 450 to 500 deg. F (230 to 260 deg. C) for three to six hours. The assembly is then cooled slowly to "de-stress" the metal.

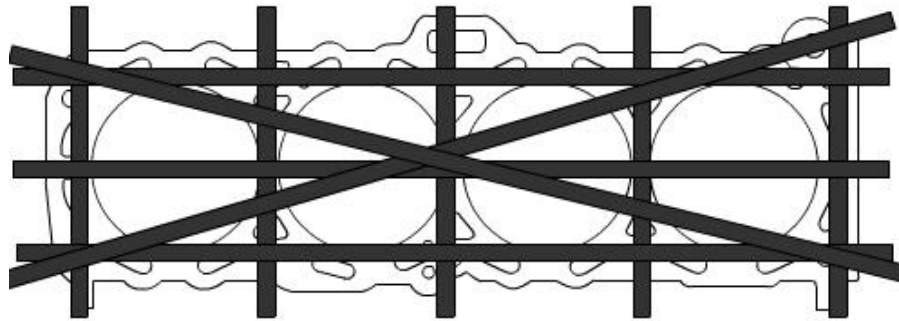
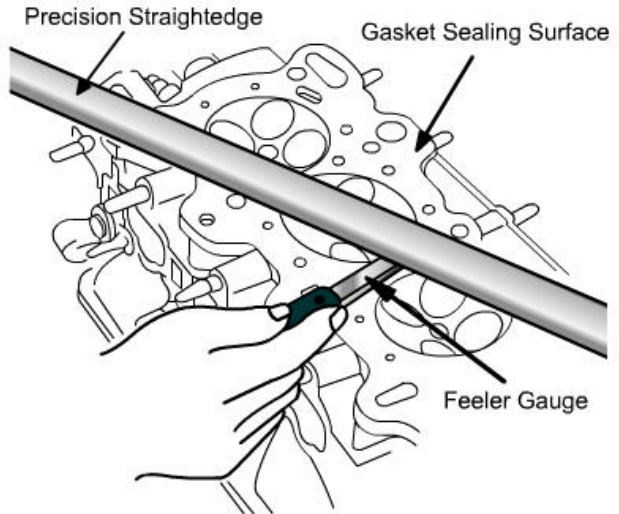

Black Lines = Straight edge Positions for Warpage Check

Disassembly and Visual Inspection for Cracks

After checking for warpage, a close visual inspection should also be made for hairline cracks in the combustion chambers, ports, face, sides and top of the head. Be sure to examine the spark plug, glow plug and/or injector holes for damaged threads and cracks. Look closely around the head bolt holes for cracks and evidence of coolant leakage. Many cracks can be very difficult to see. Keep in mind that there may be cracks that aren't visible even under close scrutiny.

If a crack is found, don't do anything else to the head until it is determined if the crack is repairable. In most cases, a cracked cylinder head will need to be replaced.

If no cracks are found after a close visual inspection, the valves and springs can be disassembled. Make sure to mark and record the location of each valve as it is removed.

The tips of the valve stems may have become **mushroomed** or enlarged from being pounded by the rocker arms. This can happen after an engine has been run for long periods of time with excessive valve clearance.

Any valve that has a mushroomed stem should have the "mushrooming" filed off before the valve is removed.

- **Don't try to drive mushroomed valves out with a hammer and punch – this will damage the valve guide!**

After the valves are out, carefully clean the carbon from the ports and valve guides. A wire brush in an electric drill can be used on cast iron heads; aluminum heads should be cleaned by hand using a gasket scraper or carbon removal tool. Chemical carbon removers can help soften tough deposits.

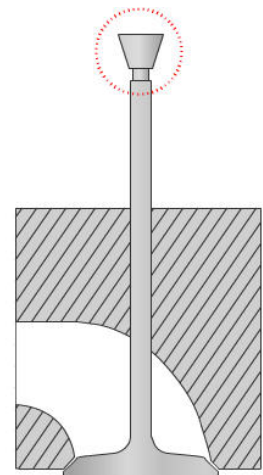

Mushroomed Valve Tip

- **Be careful not to gouge or scratch machined surfaces when cleaning aluminum heads.**

Inspect the valve springs for squareness and signs of wear or damage. Measure their free height. To do this, stand all of the springs on a flat surface next to each other. They should stand the same height and should stand squarely. If there is any discrepancy in their height or if any of the springs do not stand squarely, replace all of the springs.

- **The tension of each valve spring can be tested using a special gauge. Extensive testing of valve springs is generally not cost effective. In most cases, it is cheaper to replace questionable valve springs than it is to test them, particularly in a high-mileage engine.**

Next, the valve seats along with the area under the valves should be checked visually for damage or cracks. If any of the valve seats appear damaged, loose, or pitted, they should be replaced or repaired. This is another job that most shops will sublet out to an automotive machine shop.

As noted previously, there still may be cracks that are not visible even under close inspection. It is therefore recommended that the cylinder head be **pressure tested** before any further inspection or machine work is performed. Pressure testing requires sealing up all the water openings in the head and applying regulated air pressure to the cooling jackets. Leaks are revealed by submerging the head in a tank of water or spraying it with soapy water. Bubbles indicate leakage. There are other ways to look for cracks. A **magnetic particle crack detector** can be used on cast iron heads, and a **spray-on dye penetrant** that glows under ultraviolet light can be used on aluminum heads. Crack detection is another job that most shops will sublet out to an automotive machine shop.

Valve and Guide Inspection

The contact area of each valve where it rests on the valve seat is called the **face**. The valve face and seat are what actually seal the intake and exhaust ports when the valves are closed. Both of these areas are precision machined.

As well as providing a seal, this valve face / valve seat contact area also allows the heat of combustion to be transferred from the valve to the seat and water jacket while the valve is closed. The high temperatures found in the combustion chamber would rapidly burn away the face and seat of any valve that does not make solid contact when closed, especially in the case of an exhaust valve.

The valvetrain is designed to rotate every valve slightly with each opening and closing event. This is done to help equalize valve seat and face wear.

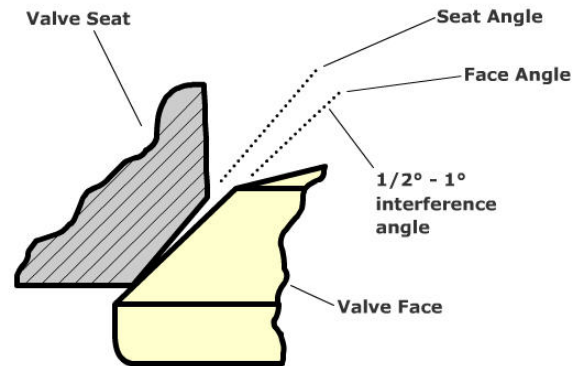

Valve Seat and Face Angles

All valve faces and seats should be closely inspected. The contact areas should be true and shiny. The actual width of each face and seat can be measured and compared to manufacturer's specifications. Pitted or obviously worn seats and faces should be reconditioned. Worn valves and seats can sometimes be resurfaced by cutting or grinding using special tools, but if they are severely worn replacement may be required. Severely burnt valves will have a section of the face burned or melted away and should be replaced.

Valve guides will always wear keyhole-style in a direction that is perpendicular or sideways to the length of the cylinder head. This wear occurs because the valvetrain loads the valve in this direction as the valve is opened and closed.

Check for valve and guide wear by reinserting the valve into its corresponding guide. Hold the valve in its approximate open position a quarter inch (6.5 mm) off of the valve seat. With the valve in this position, wiggle the valve back and forth crosswise (at a 90 degree angle) to the head. With the valve in this position, wiggle the valve back and forth crosswise (at a 90 degree angle) to the head. If you can feel movement or play, the guide or valve stem is worn.

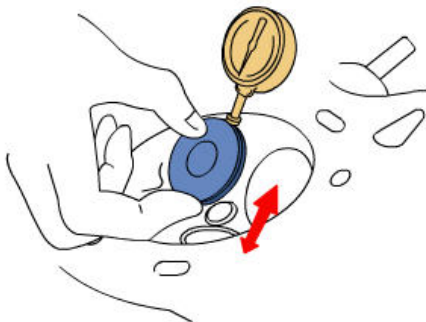

A dial indicator can be used to measure the actual amount of play. Set up the dial indicator to contact the edge of the valve when it is in its normal open position so that it will indicate crosswise movement. As noted earlier, this should be a quarter inch (6.5 mm) off of the valve seat. Note any indication of movement on the dial.

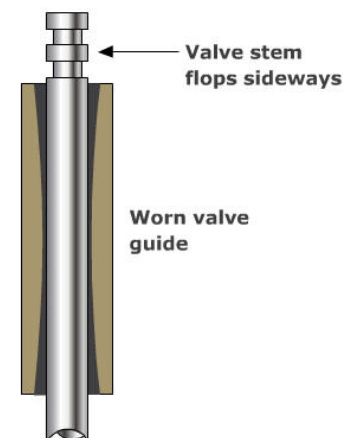

Valve guides can also be measured for roundness and diameter using a small-hole measuring gauge. If wear is detected, a micrometer can be used to measure the valve stems for wear and taper. Micrometer use is covered in the Today's Class Brakes course.

Replace all valves that have stems that are worn or tapered more than the vehicle manufacturer's published specifications.

If the valve stems are tapered and the guides are worn, new valves can often be purchased with oversized stems. The valve guides can then be reamed to the right diameter to fit the new stems. Some valve guides are replaceable. Integral or non-replaceable guides can be reamed out and then bushed back down to factory size using an insert.

Cylinder Head Reconditioning

Cylinder head reconditioning operations are outside the scope of this course. Most modern automotive repair shops will sublet cylinder block and head reconditioning and machine work out to an automotive machine shop.

Cylinder Head Reinstallation

As with cylinder head removal, there are so many different vehicle designs, engine and drivetrain configurations, and other variables that it would be impossible to come up with a valid, generic set of reinstallation instructions. Key points and reminders are noted here.

- **When reinstalling a cylinder head, follow manufacturer's specific published service procedures and instructions for the vehicle that you're working on.**
- **Also follow standard safety guidelines and procedures when using engine cranes and stands, lifting equipment and safety stands.**
- **Manufacturer's specific service procedures detailing component and fastener removal or installation sequence and fastener torque should be followed to the letter.**
- **Carefully inspect both the head and the block. Make sure that there is no head or block damage that will affect the sealing of the gasket. The cylinder head and block gasket surfaces should be clean and free of all old gasket materials and sealer.**
- **Head bolt holes in the block should be cleaned with a tap or thread chaser. After cleaning, use compressed air to blow out any loose debris.**
- **If head bolts are to be reused, they should be cleaned on a wire wheel. Torque-to-yield head bolts cannot be reused and must be replaced.**
- **Follow manufacturer's specific published service procedures and recommendations for applying lubricant or sealant to head bolts. Don't apply lubricant or sealant unless one or the other is specifically called for.**

Valvetrain Diagnosis and Repair

Inspecting Overhead Camshaft Valvetrain Components

Overhead camshaft valvetrain components are easily inspected as the cylinder head is being disassembled for service. In many cases, a close visual inspection will suffice. Cam lobe measurements can be taken if there's a doubt about lobe wear, but visual comparison of multiple lobes should make it easy to note one or more that are worn.

- **Manufacturer's specific service procedures detailing component and fastener removal sequence, component inspection and fastener torque should be followed to the letter.**
- **Be sure to mark rocker arms and/or cam followers and keep them in order during disassembly and inspection. Do not mix them up when reassembling them. Match them to the same cam lobe that they were removed from. Failure to do this will cause rapid cam lobe, rocker arm and/or cam follower wear.**
- **The contact surfaces of the cam lobes and rocker arms and/or cam followers are some of the highest friction points in an engine. If a cam lobe is worn, replace the cam and ALL rocker arms and/or cam followers. Never run used rocker arms and/or cam followers on a new camshaft, or new rocker arms and/or cam followers on a used cam. Rapid wear will result.**

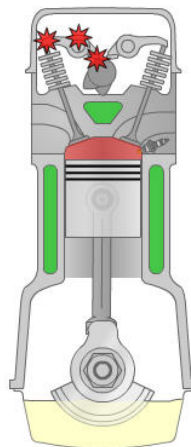

OHC Valvetrain Wear Points

Visually inspect cam lobes and rocker arms / followers for signs of scoring or excessive wear at their three contact points.

Cam lobes and rocker arms/followers can be compared from cylinder to cylinder to detect abnormal or uneven wear.

Cam bearings and journals can be measured and inspected with the cam removed.

Inspecting Pushrod Valvetrain Components

A visual inspection of the camshaft itself in a pushrod engine requires that the camshaft be removed. If a worn cam lobe is suspected, pushrod travel for each valve individually can be measured with a dial indicator while rotating the crankshaft. A visual comparison of how far each pushrod and rocker arm moves as the crankshaft is rotated may be enough to find a worn cam lobe.

Rocker Arm: Visually inspect all rocker arms for signs of scoring or excessive wear at their contact points. Some engines use a separate pivot which should also be inspected for excessive wear. Some rocker arms are shaft-mounted; the shafts need to be closely inspected as well. Excessively worn parts should be replaced. In some instances, the bearing that contacts the rocker shaft can be replaced. In other cases, the pad that contacts the valve stem can be replaced.

Rocker Arm Pivot and Stud: Some engines use pressed-in studs to mount each rocker arm and pivot. The installed length of all pressed-in studs should be measured to be sure that they have not started to back out of the head. If any stud is significantly longer than the others, the head must be repaired by a qualified machinist.

Some engines use screw-in studs. A popular performance modification to small-block Chevrolet V8 cylinder heads is to convert press-in studs to the screw-in type. Screw-in studs are less likely to pull out when used with high lift camshafts and stiffer valve springs. Other engines use bolts and pedestals to retain the rocker arms.

Regardless of the attachment method, all attaching hardware and threads need to be inspected for wear and distortion. This includes threads in the head. If there's any doubt as to the condition of the attaching hardware and pivots they should be replaced.

Pushrod: Carefully inspect both ends of each pushrod. Make sure each end is smooth and rounded. Any roughness or distortion is reason for replacement. Roll each pushrod on a flat surface after removing them. Pushrods that are bent do not roll smoothly. Replace all bent pushrods. When reusing pushrods, make sure that they are clean inside if they carry oil to the rocker arms (as with a small-block Chevrolet V8, for example).

Lifter or Tappet: You will typically find two types of lifters in most modern engines.

Roller lifters or tappets (the terms lifter and tappet are interchangeable) contact the camshaft lobe via a small roller to reduce friction. Our example OHV engine uses these.

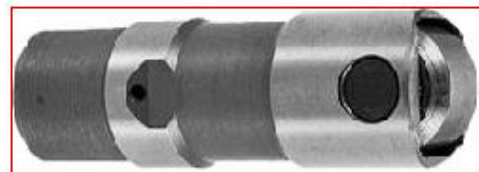

Roller Tappet

Flat tappets are not truly flat - they have a slightly convex base that contacts the camshaft lobe. Flat tappet camshaft lobes are ground at an angle close to that of the convex tappet base. This is done to rotate the lifter in its bore with each valve opening/closing event, which promotes even contact area wear.

Visually inspect the valve lifter base or roller for roughness and damage. If any damage is found on any lifter that contacts the camshaft, replace all of the lifters and the camshaft.

- **Manufacturer's specific service procedures detailing component and fastener removal sequence, component inspection and fastener torque should be followed to the letter.**
- **Be sure to mark lifters/tappets and keep them in order during disassembly and inspection. Do not mix them up when reassembling them. Match them to the same cam lobe that they were removed from if they are to be reused. Failure to do this will cause rapid cam lobe, rocker arm and/or cam follower wear.**



Flat Tappet

- **The contact surfaces of the lifters/tappets are some of the highest friction points in an engine. If a cam lobe is worn, replace the cam and ALL lifters. Never run used lifters on a new camshaft, or new lifters on a used cam. Rapid wear will result.**

Mechanical and Hydraulic Lifters

A small clearance has to be left between the valve and its actuating mechanism to allow for thermal expansion and wear. Valves must always close and contact their seats completely. A valve that does not close completely would rapidly burn away at the face and seat areas, especially in the case of the exhaust valve. Engines using mechanical lifters require periodic valve clearance (lash) adjustment. Mechanical (solid) lifters are of a fixed length.

The hydraulic lifter was designed to ensure that the valvetrain always operates with zero clearance, leading to quieter operation and eliminating the need for periodic adjustment of valve clearance.

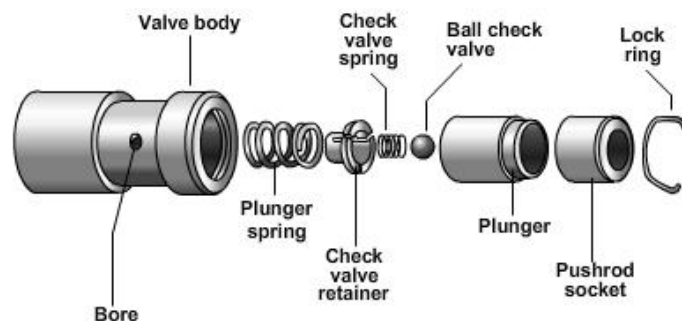

Inside a Hydraulic Lifter

These lifters are designed to automatically adjust their lengths to maintain zero valvetrain clearance. This length adjustment is accomplished using engine oil pressure along with simple valving inside the lifter itself.

Valve Lash Adjustment

As stated earlier, both hydraulic and mechanical valve train clearance must be set when the valve train is assembled. Mechanical valve train clearance must also be maintained by periodic measurement and adjustment. Hydraulic valve clearance will be automatically maintained making periodic maintenance unnecessary.

Methods for adjusting valve lash (clearance) vary, depending on both engine design and the design of the valve lifter. There are so many different vehicle designs, engine and valvetrain configurations, and other variables that it would be impossible to come up with a valid, generic set of lash adjustment instructions.

- **Manufacturer's specific service procedures detailing component and fastener removal sequence, lash adjustment and fastener torque should be followed to the letter.**

Camshaft Drive Components

As noted earlier, the camshaft must open and close each valve at exactly the right time relative to piston position. This is accomplished via the cam drive. The camshaft is driven by the crankshaft via one of three methods:

Chain Drive, which uses a **Timing Chain** and **Sprockets**. Chains used on overhead cam engines typically use a chain tensioner and guide rails as shown here. The tensioner can use an internal spring (mechanical) or engine oil pressure (hydraulic) to maintain chain tension. Most chains used in cam-in-block engine designs do not use guide rails or tensioners because the chain length is much shorter.

Belt Drive, which uses a **Timing Belt** along with **Pulleys** and/or **Sprockets**. Belts are lighter and quieter than timing chains. They also do not require engine oil lubrication. As with overhead cam chain drives, tensioners can be mechanical or hydraulic. Guide pulleys are used rather than guide rails where needed.

Gear Drive, which uses two or more **Gears** meshed directly. Very few modern gasoline engines use direct gear drive between the cam and crank, though some diesel truck and equipment engines still do.



Chain Drive



Belt drive, left; Gear drive, below



Camshaft Drive Component Inspection, Adjustment, Replacement

The timing chain and sprockets should be replaced as a set if the chain is stretched or the sprockets are worn past manufacturer's specifications. Some timing chain sprockets have nylon or plastic teeth to reduce noise. These can fatigue and break with heat and age. When these teeth break they wind up in the oil pan. Cleaning these pieces out should be a part of the timing chain replacement job as they can stop up the oil sump pickup screen.

Gears in a gear drive arrangement should be replaced as a set as well. Mixing new gears with old, worn ones will result in increased noise and accelerated wear.

Engines that use a toothed belt (sometimes there are more than one) to drive the camshaft generally have a recommended belt replacement interval. Consult manufacturer's service information for this information.

Timing belts also sometimes drive other engine components besides the camshaft(s). This varies with engine design – some designs use the timing belt(s) to drive the water pump, oil pump, or balance shafts. Belt breakage can occur if any one of these components seizes.

Timing belts can also become oil or coolant-soaked if nearby gaskets or seals are leaking. Failure to fix the leak before replacing the belt will result in rapid deterioration and possible premature failure of the new belt.

Any time a timing belt is being removed it is good practice to replace it regardless of age. An exception to this would be if the belt has recently been replaced, and is being removed to access another component. When and if in doubt, replace.

Any vehicle that comes into the shop with a broken camshaft drive belt or chain should be checked for valvetrain or piston damage. Vehicles where the belt or chain didn't break but got loose enough to get the crank and cam severely out of time should be checked as well.

Some engines use what is called an **interference** design. This means that if the crank and cam get far enough out of time while they are turning that the pistons will hit any open valves. The result is valve, valvetrain, or piston damage.

Other engines use what is called a **freewheeling** design. This means that the engine is designed with enough piston-to-valve clearance to keep these parts from colliding even if the crank and cam get out of time while they are turning.

Timing chain or belt replacement on some vehicles may require special tools. Some belt pulleys, gears, or chain sprockets may be press-fitted onto the camshaft, crankshaft, or auxiliary shaft. Specific pullers and/or installers may be required to service these items.

- **Manufacturer's specific service procedures detailing component and fastener removal sequence, component inspection, adjustment, or replacement, and fastener torque should be followed to the letter.**

Unit 4 – Engine Block Diagnosis and Repair

Unit Objective:

After completion of this unit, students should be able to identify cylinder block components and functions and perform diagnostic and repair procedures on those components

Specific Objectives:

- Identify engine block associated terms and definitions.
- Understand and be able to explain the construction and function of the engine block
- Understand and be able to explain the procedures for:
 - cylinder block removal, disassembly, and inspection
 - inspecting and measuring the cylinder block
 - checking and recording cylinder block component measurements
 - reconditioning cylinder walls
 - removing and replacing piston pins
 - reassembling the engine

Engine Block Function and Construction

By this point in the course, you should have experienced engine removal, disassembly, and component checking for all common engine components down to the **engine block**, **crankshaft and bearings**, **pistons**, **pins** and **piston rings**, and **connecting rods and bearings**.

When assembled, this list of components is commonly referred to as a **short block**.

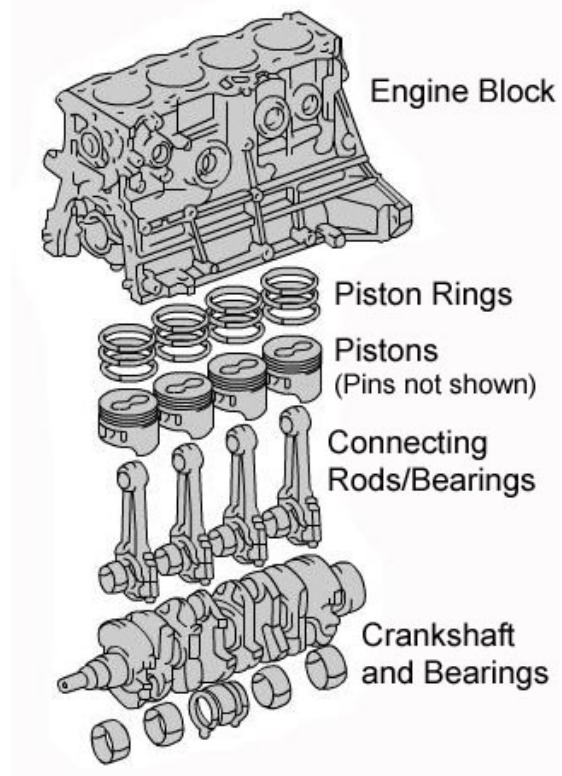

Exploded View of a Four-Cylinder Short Block

Short Block Inspection and Disassembly

Disassembly and inspection of the short block and individual components begins with the engine bolted to an engine stand. The engine will have been removed from the vehicle, and the cylinder head and other external components will have been removed as per manufacturer's service procedure.

- **Manufacturer's specific service procedures detailing short block disassembly, fastener removal sequence, component inspection and fastener torque should be followed to the letter.**

If you break a bolt or strip threads in the cylinder block where bolt-on parts attach during disassembly, make note of this. Don't try to extract a broken bolt or perform a thread repair on the block until after the block has been inspected thoroughly. There's no sense in fixing a block that an inspection may show needs replacement instead of reconditioning.

Be sure to clean the head gasket surface on the cylinder block deck once the external bolt-on parts have been removed.

- **Use a gasket scraper to remove debris and gasket residue from the cylinder block deck as previously discussed. Cleaning gasket surfaces with surface conditioning disks is NOT recommended by vehicle manufacturers.**

Short Block Inspection

Knowing the specific customer complaint (as discussed earlier) can help you find what you're looking for when inspecting the short block. For example, cooling system concerns, like overheating and loss of engine coolant, can in many cases be traced to a cracked block. Oil consumption complaints can sometimes be traced to worn piston rings and cylinders. Misfire and power loss complaints are sometimes caused by cracked or burned pistons that cannot keep the pressure of combustion confined to the inside of the cylinder.

In addition, you may find that in some cases that replacing a worn, high-mileage short block or complete engine with one that is new or reconditioned makes the most economic sense for the vehicle owner.

Warpage Check

Check the **block deck surface** for warpage using a **precision straightedge** and a set of thin **feeler gauges** in the same manner as discussed previously when checking cylinder heads.

As a general guideline, warpage lengthwise should not measure more than .003 in. (0.076 mm) for a three cylinder (V6) block, .004 in. (0.102 mm) for a four cylinder or V8 block, or .006 in. (0.152 mm) for a straight six block. When measuring side-to-side, the maximum allowable limit for warpage for any cylinder block is .002 in. (.05 mm)

- **Manufacturer's specific specifications for warpage should be followed to the letter. The figures given here are general guidelines.**

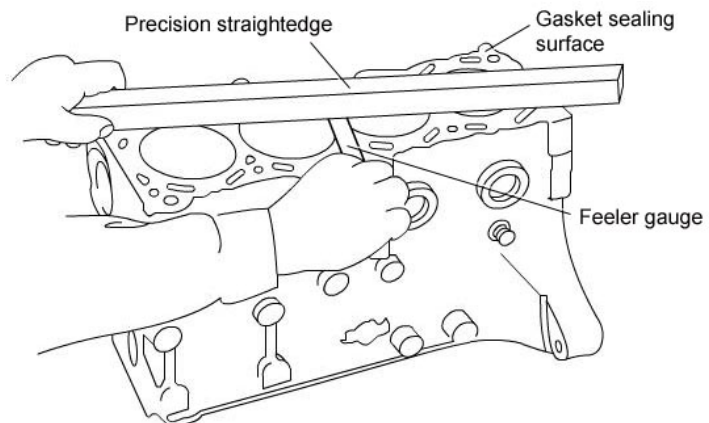

Checking Block Deck for Warpage

Cylinder block deck surfaces that are warped beyond manufacturers' specifications can generally be trued by milling. As with milling cylinder heads, this is typically a job that most shops will sublet out to an automotive machine shop.

Disassembly and Visual Inspection for Cracks

After checking for warpage, a close visual inspection should also be made for hairline cracks in the cylinder bores, deck surfaces, sides and top of the block. Look closely around the head bolt holes and coolant passages in the block deck surface for cracks and evidence of coolant leakage. Many cracks can be very difficult to see. Keep in mind that there may be cracks that aren't visible even under close scrutiny.

If a crack is found, don't do anything else to the block until it is determined if the crack is repairable. In most cases, a cracked cylinder block will need to be replaced. If no cracks are found after a close visual inspection, continue with disassembly.

Areas to Inspect For Cracks

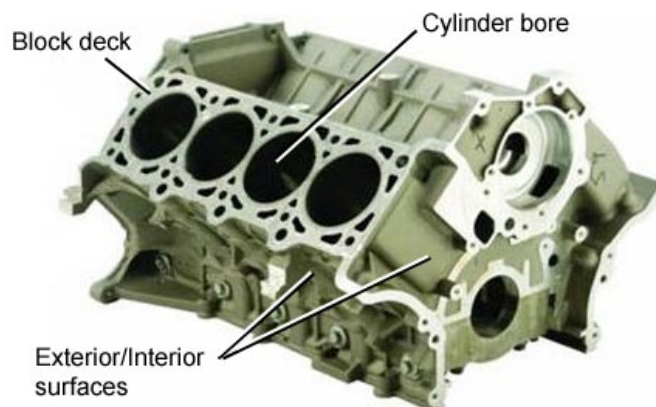

Cylinder Bore Wear

Cylinder bores do not wear evenly from top to bottom, for a number of reasons. The top of each cylinder bore is subjected to a high “spike” of cylinder pressure as the air/fuel mixture ignites. This pressure “spike” forces the piston rings against the cylinder wall as the piston and connecting rod are pushed down. In addition, the very top of the bore receives the least amount of lubrication. A **ring ridge** forms at the tops of the cylinder walls of high-mileage engines as a result.

This ring ridge may be large enough to interfere with the pistons and rings when the pistons are removed from the bores. Use your fingernail to feel for a ring ridge at the top of the bore. If there's enough of a ridge to catch your fingernail it will need to be removed before removing the pistons.

A tool called a **ridge reamer** is used to cut the ridge down without marring the piston ring contact area of the cylinder wall below the ridge itself.

Once any existing ring ridge has been cut away, the pistons and rods can be removed.

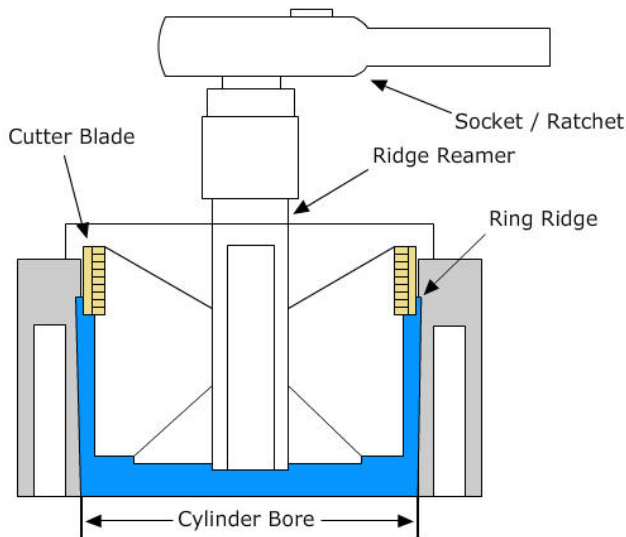
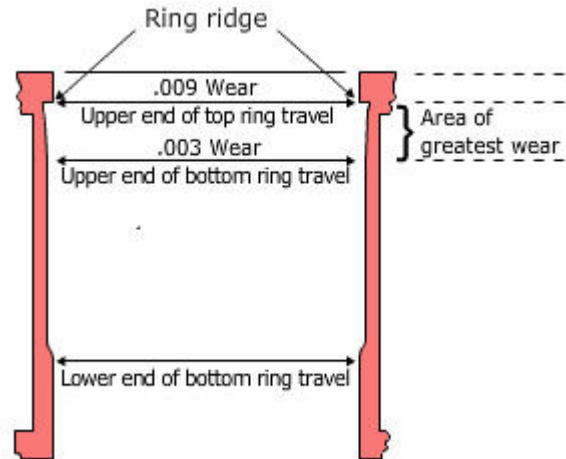

Ridge Reamer

- **Be careful not to drop the pistons as they come out of the block.**
- **If the piston rings hang up on the ring ridge, remove the ridge as previously discussed. Never force the piston assembly past the ridge - doing so may damage the piston.**
- **Do not mix up the connecting rods and rod caps.**

Once each piston is out of the block, put each rod cap back on the corresponding connecting rod. Do not remove the connecting rod bearing shells yet.

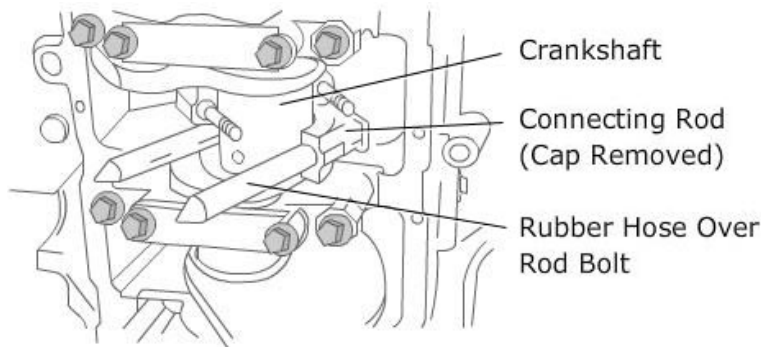

Piston and Rod Removal

Before unbolting the connecting rod cap, rotate the crankshaft so that the piston and rod to be removed are at bottom dead center (BDC). Each connecting rod and cap should be numbered by the manufacturer as shown.

Each connecting rod and rod cap is machined as a set when the engine is built. They are to be kept together, so if they are not already marked, number them by cylinder using a punch stamp.

Next, remove the rod cap nuts and separate the rod cap from the connecting rod. This may require a tap with a plastic or non-marring hammer to jolt the rod cap loose.

Place a piece of rubber hose over each rod bolt before moving the piston and connecting rod assembly to protect the crankshaft bearing surface from being scratched.

The piston and connecting rod assembly can then be pushed out of the top of the cylinder bore. A hammer handle can be used to push on the bottom of the piston if you need more leverage.

Connecting Rod and Cap Numbers



Crankshaft Removal

If the main bearing caps are not already numbered by the manufacturer, number them for assembly. Note also that most main bearing caps have an arrow cast into them that should point towards the front of the engine.

Next, remove all the main bearing cap bolts. Keep them in order so that they can be placed in the proper positions during reassembly. On some engines, main cap bolts are of different lengths. If these bolts are placed in the wrong location, the main bearings will fail quickly once the engine is run. Remove the rear main seal if it is a one-piece design before lifting the crankshaft out of the block.

The main bearing caps, like the rod caps, may require a tap from a non-marring hammer to loosen them from the engine block. Remove the caps one at a time and set them aside. Do not remove the main bearing shells yet.

Once all of the main bearing caps have been removed, carefully lift the crankshaft out of the block.

Crankshafts in some engines can be extremely heavy, so this may be a two-person job.

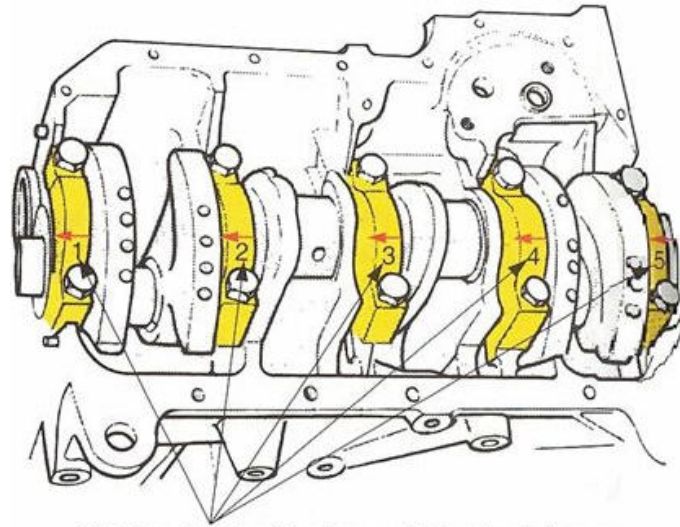

Main Bearing Cap Numbers and Directional Arrows

- **Follow standard safety guidelines and procedures when lifting heavy parts or using lifting equipment.**

Crankshaft, Bearing, and Piston Inspection

With the pistons and crankshaft removed, all wear areas, including the main and connecting rod **bearing halves**, the crankshaft **journals**, the **pistons** and the **cylinder bores** can be visually inspected for obvious problems.

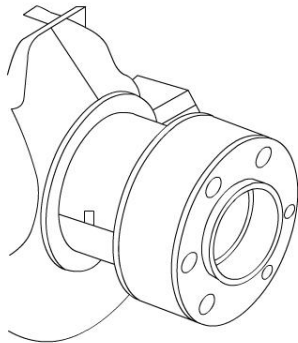

Flywheel Flange

Crankshaft inspection begins with the **flywheel flange** and pilot bushing (where applicable). Look for signs of wear, cracks, or defects. Be sure to check the threaded flexplate / flywheel bolt holes for stripped threads. The area of the crankshaft where the rear main seal rides should also be inspected for wear and grooving.

Inspect the nose of the crankshaft. The crankshaft balancer **woodruff key and keyway** should be examined for wear, and the threaded balancer bolt hole should be checked for pulled or stripped threads. The area of the crankshaft where the front seal rides should also be inspected for wear and grooving.

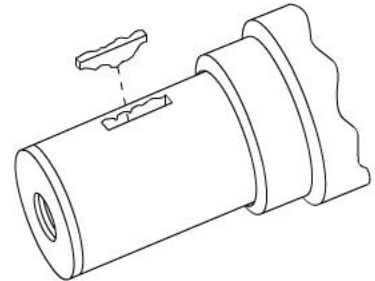

Nose of Crankshaft

Next, inspect the rod and main bearing journals. All crankshaft journals should be smooth with no evidence of scoring or damage **(1)**. If deep grooves **(2)**, scratches or uneven wear **(3)**, or pitted surfaces **(4)** are evident, all journals will have to be ground to a standard undersize by a machine shop to remove these imperfections.

Uneven main journal wear in the form of scratches or scuffs that don't go all the way around the journal can be an indicator of a bent crankshaft, or of out-of-line main bearing bores. Uneven rod journal wear in the same manner can indicate a bent or twisted connecting rod or a bent crankshaft. Have an automotive machine shop check the crankshaft and connecting rods for straightness as necessary. If all of the crankshaft journals are smooth, they should each be measured for taper and roundness using a micrometer.

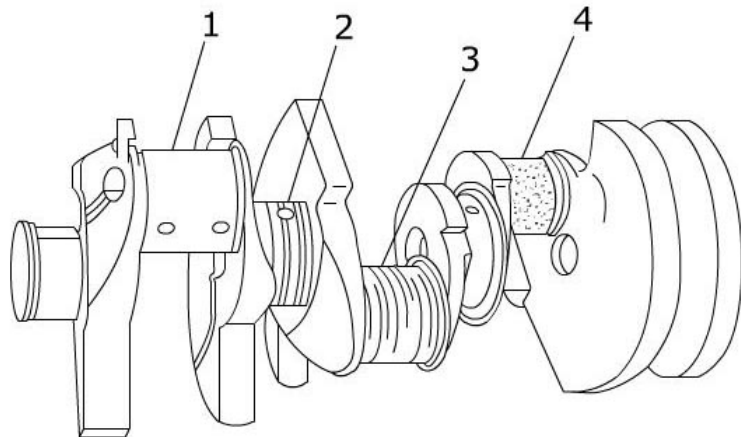

Compare your measurements to manufacturers' published service specifications. This will determine if the journals need to be ground to a standard undersize by a machine shop. If the crankshaft journals are ground undersize, matching replacement bearings sized to the new journal diameters should be fitted.

- **Manufacturer's specific service procedures detailing crankshaft journal measurements and specifications should be followed to the letter.**

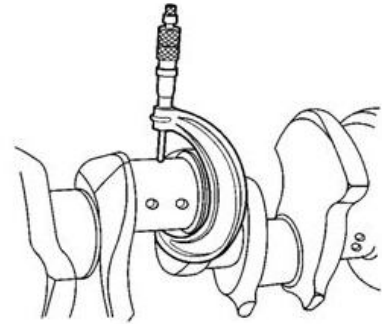
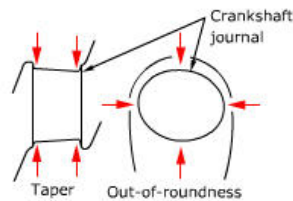

Measuring Crankshaft Journals

Even if the crankshaft bearing surfaces are all in good shape, and measure within specifications for roundness and taper, new bearings should be installed and bearing clearances should be checked during short block reassembly.

If the crankshaft is to be reused, a **magnetic particle crack detector** should be used to check for cracks that may not be seen during a visual inspection. Most shops will sublet this out to an automotive machine shop.

Next, inspect all used main and rod bearing halves for unusual wear patterns. Remove the bearing halves from their bores one at a time as you inspect them.

- **Manufacturer's specific service procedures detailing bearing removal and inspection should be followed to the letter.**

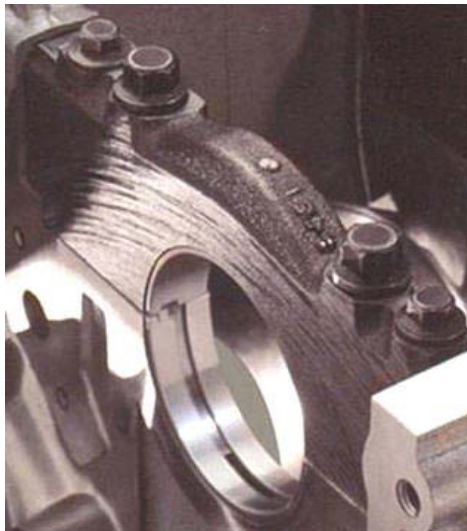

Look for signs of flaking, melting, or damage caused by foreign material or a restriction in the lubrication system. Other conditions to look for include excessive scoring or discoloration, dirt or debris imbedded into the bearing material, and craters or pockets in the bearing surfaces. Flattened sections on the bearing halves indicate fatigue from pounding against the crankshaft journal. Improper seating of bearings in their bores can be indicated by bright, polished sections of the bearing surface.

Bearings & Bores

The connecting rod and main bearing bores are precision-machined to precise tolerances. The bearing halves themselves are also sized precisely so that they are an interference (snap) fit into each bearing bore.

Tabs at the ends of each bearing half maintain their fore-and-aft location. The groove shown in the upper bearing half supplies oil to the bearing surface and crankshaft journal.

Main Bearing Halves and Main Cap Installed in the Block

In severe cases of lack of lubrication, the bearing halves can gall and literally weld themselves to the crankshaft journals. When this happens, these normally stationary bearing halves can rotate in their bores, damaging the bearing bore surface. The result is what is referred to as a "spun bearing."

Typically the connecting rod and cap or main bearing bore and cap must be resized by a competent machinist to correct this. In extreme cases the connecting rod or cylinder block must be replaced.

Spun Connecting Rod Bearing



Pistons

The pistons should come next in the inspection process. Each piston should be examined for cracks, holes, scuffing or excessive pitting.

- **Cracks in the piston will usually be located near the piston pin and/or skirt.**

If scuffing is found on the sides of the piston, examine the cylinder that the scuffed piston was removed from. If scuffing is found on the cylinder wall, all cylinders will most likely need to be bored oversize. All pistons would then be replaced.

The areas between the grooves in the piston that hold the piston rings are called **ring lands**. Pay particular attention the ring land area for signs of stuck rings, broken lands, or broken rings. Using a feeler gauge, measure the clearance between the rings and the ring lands and compare to service specifications.

- **Manufacturer's specific service procedures detailing piston service and inspection should be followed to the letter.**



Scuffed Piston

Piston diameter can be measured using a micrometer, though most automotive repair shops will leave piston and piston-to-bore clearance measurements to a machine shop.

If the piston passes all inspections and will be reused, remove the rings and use a ring groove cleaner or an old broken piston ring to remove the carbon from the piston ring grooves. Also, clean the top of the piston with a scraper. A wire brush is not recommended for use when cleaning pistons because of the potential for damage.

Secondary Block Inspection

A second visual inspection focusing on the cylinder bores and the bottom of the block should be made after crankshaft removal. Inspect the following areas:

- The cylinder wall surfaces for scratches, gouging, and pitting. If any of these conditions are found, the cylinders may need to be bored oversize (if possible) to remove them.
- The coolant jackets for cracks
- The valve lifter bores for excessive scoring or wear
- The crankshaft bearing webs for cracks
- The gasket sealing surfaces for excessive scratches or gouging
- The oil galleries for restrictions (as best is as visually possible)
- All threaded bolt holes for damage

Short Block Reconditioning

By this point in your inspection and evaluation of the short block, obvious problems will have been found if they exist. If it makes sense from a time, condition and economic standpoint to continue the engine reconditioning process, most modern automotive repair shops will sublet the disassembled short block out to an automotive machine shop. There, the camshaft bearings (where applicable), oil gallery plugs and freeze plugs will be removed from the block. The short block and parts will then be thoroughly cleaned, and the machinist will perform a crack check using a magnetic particle or dye penetrant detection process. If all of the parts pass this check, the machinist will then take careful measurements of the cylinder and bearing bores, crankshaft journals, pistons and connecting rods to determine what machine work and new parts will be required for reconditioning.

Short Block Reassembly

A generic overview and important points of the assembly process are provided here. In most cases, the crankshaft bearings and crankshaft are installed first. Install the bearings into the engine block and main caps and carefully set the crankshaft into place as per manufacturers' instructions.

- **Manufacturer's specific service procedures detailing short block assembly should be followed to the letter.**

Plastigage® is commonly used to check main (and connecting rod) bearing clearances during assembly. Follow the vehicle manufacturer's service procedures for checking this critical dimension and for instructions on what to do if the measured clearance is outside of specifications.



Bearing Clearance Measurement

Main and rod bearing clearances must be exactly to manufacturer's service specifications in order to have good oil pressure and a quiet, durable engine.

- **Pay particular attention to thrust bearing alignment (where applicable) during crankshaft and bearing assembly.**
- **Main bearing caps and fasteners should be installed in their correct locations.**
- **Manufacturer's specific service procedures detailing fastener torque and torquing sequence should be followed to the letter.**
- **Once the crankshaft has been installed and the main caps have been torqued down, refer to manufacturer's specific service procedures for testing that the crankshaft rotates freely.**
- **Follow manufacturer's specific service procedure for measuring crankshaft end play.**

Once the crankshaft, bearings and rear main seal have been installed, the pistons, piston rings and connecting rods should be assembled and installed. Pistons and piston pins should be installed on the connecting rods according to vehicle manufacturer's procedures.

Ring Gap

Before installing the new piston rings on the pistons, the installed piston ring **end gap** should be measured. End gap is a critical measurement. Piston rings will expand once they are subject to the heat of combustion. If the ring gap is too small, the ends of the piston ring will butt together once the rings expand. This can result in ring, piston, and cylinder wall damage. Some piston rings can be filed to widen a gap that is too small. If the ring gap is too large, the piston rings will not seal the combustion chambers off from the crankcase as they should. This can result in oil contamination and consumption as discussed in the diagnostics section of this course.

- **Manufacturer's specific service procedures detailing the measurement and correction of piston ring end gap should be followed to the letter.**

Installing Rings

Use extreme care when installing the piston rings on the pistons. The procedure for piston ring installation varies greatly from engine to engine and can even be specific to the piston ring brand or manufacturer. Most aftermarket piston ring sets contain installation instructions.

Almost all modern automotive engines use a multi-piece oil control ring assembly. This is typically installed and assembled in the bottom ring groove first. The compression rings are then installed using a **piston ring expander** tool with the top compression ring going on last.

Most compression rings will appear to be similar though some top and bottom compression rings are different in design. Compression rings must be installed in the proper groove with the proper side toward the top of the piston. Rings installed in the wrong groove or wrong side up can cause excessive oil consumption or cylinder wall damage.

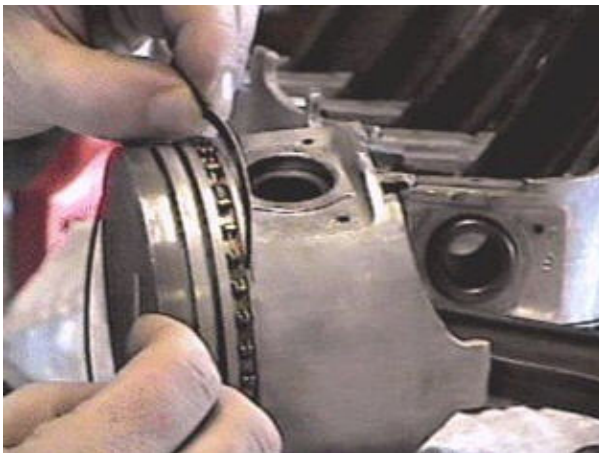

Installing Oil Control Ring



Measuring Piston Ring End Gap



Piston Ring Expander

Installing Pistons

The pistons are then installed into the cylinders. Place a piece of rubber hose over each rod bolt before moving the piston and connecting rod assembly to protect the crankshaft bearing surface from being scratched.

Orient the piston ring gaps on each piston to manufacturer's specifications and thoroughly lubricate the piston and rings in preparation for installation.

- **Manufacturer's specific service procedures detailing piston ring installation should be followed to the letter.**

**Journal Protection****Piston Ring Compressor**

A tool called a piston ring compressor is used to hold the rings at a small enough diameter to go into the block. Once the tool is applied to the piston and the rings are compressed, a hammer handle can be used as shown to lightly tap the piston into the cylinder bore.

- ***Pay particular attention to the orientation or direction of the pistons when installing them. Many pistons will have an arrow or notch on the piston top that should point to the front of the engine when installed.***

Rod Clearance

As noted earlier, **Plastigage®** is commonly used to check connecting rod bearing clearances during assembly. Connecting rod side clearance needs to be measured using a feeler gauge as well.

Follow the vehicle manufacturer's service procedures for checking these critical dimensions and for instructions on what to do if any measured clearance is outside of specifications. Connecting rod bearing clearances must be exactly to manufacturer's service specifications in order to have good oil pressure and a quiet, durable engine.

- ***Connecting rod bearing caps and fasteners should be installed in their correct locations.***
- ***Manufacturer's specific service procedures detailing fastener torque and torquing sequence should be followed to the letter.***
- ***Follow manufacturer's specific service procedure for measuring connecting rod side clearance.***

Follow manufacturer's specific service procedures and specifications for completing engine assembly, adjustments, and startup or run-in.

Portions of materials contained herein have been reprinted with permission of General Motors Corporation, Service Operations License Agreement #0410610