

MLR: Brakes Study Guide

Table of Contents

MLR: Brakes	1
Unit 1: Brakes Overview	2
Chapter 1: Brake System Fundamentals	2
Chapter 2: Brake Diagnosis Procedures	5
Unit 2: Hydraulic System	10
Chapter 1: Introduction to the Hydraulic System	10
Chapter 2: Servicing the Hydraulic System	17
Unit 3: Drum Brakes	32
Chapter 1: Introduction to Drum Brakes.....	32
Chapter 2: Servicing Drum Brakes.....	35
Unit 4: Disk Brakes.....	46
Chapter 1: Introduction and Servicing Calipers.....	46
Chapter 2: Rotors	52
Unit 5: Power Assist Systems.....	57
Chapter 1: Power Assist Systems Overview and Diagnosis.....	57
Unit 6: WHEEL BEARINGS, PARKING BRAKES, AND BRAKE LIGHTS AND CIRCUITS	60
Chapter 1: Wheel Bearings.....	60
Chapter 2: Parking Brakes and Brake Light Systems	64
Unit 7: Abs and Traction and Stability Control Systems	69
Chapter 1: Systems and Components	69
Stability Control System Function and Components.....	73
Chapter 2: Antilock Brake System Diagnosis and Service	74

Unit 1: Brakes Overview

Chapter 1: Brake System Fundamentals

Automotive brakes are designed to slow and stop a vehicle by transforming **kinetic energy** (motion energy) into heat energy. Faster speeds, heavier vehicles, and quicker stops equal more heat.

Principles of Friction

Friction is the resistance to movement that results from two objects moving or rubbing against each other. There are two types of friction: **kinetic** and **static**.

- **Kinetic friction** occurs between two objects, one of which is moving. Kinetic friction always produces heat. The more kinetic friction produced, the more heat produced. Automotive braking systems use kinetic friction to convert the energy of a moving vehicle into heat.
- **Static friction** occurs between two objects that are stationary. Automotive braking systems use static friction to hold a vehicle while it is parked. Static friction produces no heat.

Various factors affect the amount of friction produced between two objects. Automotive brakes use relatively smooth surfaces to avoid rapid wear. Automotive brakes are applied with a great amount of pressure over a relatively large contact area. The greater the pressure applied to the brakes, with all other factors equal, the greater their stopping power.

The greater the amount of shared contact area between two objects, the greater the amount of friction the objects produce. Automotive braking systems use the largest contact area possible. The greater the contact area of a brake shoe or pad, the less heat the shoe or pad generates. Less heat allows for more friction, which makes the brakes more efficient.

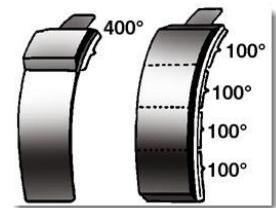

Note: On **drum brake systems**, a **brake shoe** is applied to a brake drum to create friction. On **disc brake systems**, a **brake pad** is applied to a disc to create friction.

All heat that the brake system creates must dissipate as rapidly as it is created. Brake friction surfaces are made of a material that can conduct heat easily. Braking system components that produce friction (brake shoes or brake pads) are positioned so that air cools them. In some braking systems, forced air cools the components. The amount of friction that two objects produce when rubbing against each other is called the **coefficient of friction**.

Tire Footprint

Friction Between Tire and Road

The point where a vehicle's tire contacts the road is called the tire footprint. Changes in the tire footprint affect a vehicle's ability to stop. The larger a tire's diameter is, the larger its footprint is. Larger tire footprints mean more stopping power can be applied at the tire's contact point with the road. The greater a tire's diameter, the more braking power is needed to stop the vehicle.

Note: A general rule is that the larger a tire's diameter, the more braking power required.

Wider tires have wider tire footprints. Larger tire footprints have more stopping power applied where the tire meets the road. However, keep in mind that wider tires need more braking power to stop a vehicle.

Note: A general rule is that wide tires require large brakes.

Excessive vehicle weight can distort tire tread and thereby reduce the tire's hold on the road. Tires that cannot hold the road reduce the vehicle's ability to stop. High vehicle speed can aerodynamically lift a vehicle as it moves. This lifting reduces the tire's hold on the road and reduces the vehicle's ability to stop. Tires grip the road more securely and can stop better if the wheels are moving. Stopping power decreases if the brakes lock up the wheels. If a brake system locks up the wheels too easily, this significantly reduces stopping power and vehicle control.

- Notes:**
- Aerodynamic lift merely adds to the stopping problems that high speed creates. Remember that every time a vehicle's speed doubles, the vehicle's required stopping power quadruples, even if there is no aerodynamic lift.
 - To control the vehicle, friction must occur at the tire footprint. If this friction is lost, the vehicle is out of control.

Heat and Brake Linings

An important brake friction surface is the **brake lining** that is mounted on either a brake shoe or brake pad. The brake lining produces friction by directly contacting another friction surface, either a brake drum or disc. The brake lining and the material that it touches must have the following special characteristics. The brake drum or disc must:

- Conduct heat easily
- Hold its shape under extremely high heat
- Withstand rapid temperature changes,
- Resist warping and distortion
- Wear well in general.

Brake drums and discs are typically constructed of iron or steel combined with aluminum. Brake linings must be somewhat softer than the brake drum or disc. At present, most brake linings are made of organic materials, metallic particles, and other minerals held together by a bonding agent.

Note: For years, asbestos was commonly used in brake linings. Because asbestos is a cancer-causing substance, federal law prohibits its use in brake systems.

When the brake lining is applied to a drum or disc, it is important that the proper coefficient of friction is produced in order to ensure that the brakes are effective.

- If the friction coefficient is too great, the brakes may be "grabby" or overly sensitive. Overly sensitive brakes may cause the vehicle to skid too easily.
- If the friction coefficient is too low, brake application requires excessive pressure. Applying the brakes with excessive pressure creates excessive heat that could result in brake failure.

Note: Heat always reduces the coefficient of friction between two objects. Loss of brake effectiveness due to heat created during prolonged hard braking is called **brake fade**.

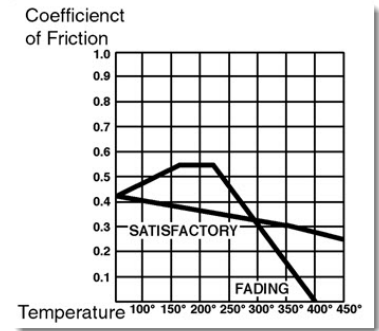

- If the brakes create more heat than they can dissipate, the friction coefficient reduces, which causes the brakes to fade.
- Excessive heat also melts brake lining bonding agents producing a glaze on the shoe lining that reduces the brake's friction coefficient and causes more brake fading. Brake application then requires more pressure, creating more heat and more glazing.

Weight and Speed

Vehicle weight

The more weight a moving vehicle has, the more kinetic energy it possesses. Brake systems must convert kinetic energy into heat. Increasing vehicle weight puts more demand on the brakes. Doubling a vehicle's weight also doubles the amount of kinetic energy brakes must convert to heat. This also doubles the amount of heat energy produced. Brakes on an overloaded vehicle may therefore become ineffective due to overheating.

Vehicle speed

When the speed of a vehicle doubles, the brakes must convert four times the amount of kinetic energy into heat. Speed greatly increases the demand on a vehicle's brakes. A combination of high speed and excessive weight may push a vehicle's brakes beyond their performance limit, resulting in a serious loss of stopping power.

Service Brakes & Parking Brakes

Automotive brake systems fall into two major categories: **service brakes** (hydraulic brakes) and **parking brakes**.

- Service brakes stop the vehicle when it is in motion.
- A parking brake holds the vehicle while it is parked. A parking brake is not designed to stop a moving vehicle.

Note: Parking brakes often use the same friction surfaces as service brakes.

Base Brake Components

Base brake components are the parts of the brake system found on all vehicles. The term "base brakes" does not include antilock brakes or traction control systems. Base brake components include:

- Brake pedal and linkage
- Power brake boost system
- Master cylinder, hoses and pipes
- Brake rotors and pads
- Brake drums and shoes
- Brake balance controls (proportioning valve and metering valve), if equipped
- Red brake warning and other warning systems
- Parking brake pedal and linkage

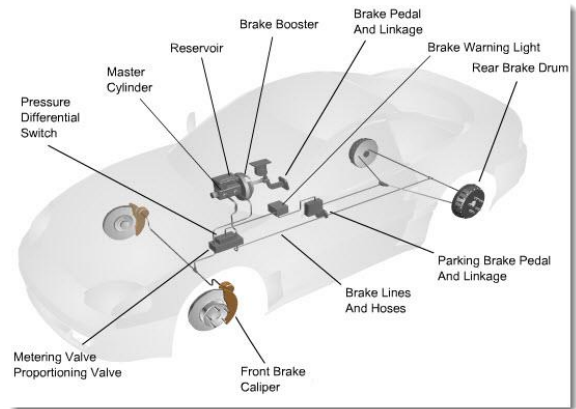

Brake Subsystems

Automotive brake systems can be broken down into several different sub-systems:

- Apply system
- Boost system
- Hydraulic system
- Wheel brakes
- Balance control system
- Warning system

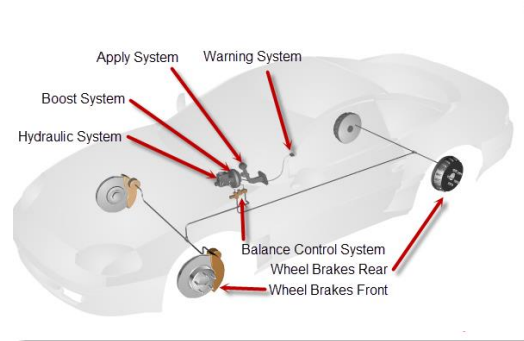

Chapter 2: Brake Diagnosis Procedures

Identify all service precautions, and review TSBs related to the vehicle's braking system. When completing the repair order, ask the owner for the vehicle's service history.

The Work Order

The automotive technician needs to be familiar with the functions and components of a work order. The work order serves several functions.

- Itemizes the repairs by listing the cost of parts and labor
- Can be used to authorize the repair
- Has the necessary information on how to contact the owner and serves as documentation for future reference
- May also specify limited warranties and liabilities of the shop
- May serve as a reference for recent service history for warranty or legal purposes

A work order typically has the following components.

- Customer name, address, and phone number (home or work with extension number)
- Date
- Invoice number
- Year, make, model, vehicle identification number (VIN), and mileage of the vehicle
- Name/initials of the service writer and technician
- Customer authorization signature to allow repairs
- Description of customer concern
- Vehicle service history information
- Related technical service bulletins (TSB)
- Technician's notes that includes diagnostic procedures performed, the results of diagnosis, and any important observations or remarks
- Component or system defect responsible for the concern
- Service performed to successfully correct the concern
- Labor procedures and costs based on the parts and labor estimation guides
- Outside labor procedures and costs that include if a shop sent a particular part out to another shop for repairs
- Listing of each part that includes name, description, and cost
- Sales tax, which is usually calculated on parts only
- Total that represents the final price that the customer will pay for all charges related to the repair

Work orders may be handwritten or prepared by entering codes in a computer terminal and then printed. Depending on the part, the following information may be required for ordering repair parts.

- Make, model, and model year (found on the driver's side door jamb) of the vehicle
- VIN
- Engine information that includes engine size, in cubic inches or liters, the number of cylinders, and the type of fuel system
- Wheelbase
- Number of doors

Brake Diagnosis - Initial Steps

Diagnosing brake problems can be simplified by following a few basic steps:

- Listen to the customer
- Verify the complaint
- Perform a visual inspection
- Conduct a brake pedal check
- Test Drive (before and after repairs)

It is very important to verify the customer's concern before beginning diagnosis of the brake system. Have the customer describe the brake system concern. Pay careful attention to what they are describing. Make sure to record what they say. Ask the customer the following series of questions. Make sure to record their answers.

- When did the concern first occur?
- Is the concern continuous or intermittent?
- Is the brake or antilock brake system warning light on or flashing?
- What are the driving conditions when the concern occurs?
- What is the recent service history of the vehicle?
- Is the vehicle making any unusual noises?
- Does the vehicle pull during braking?

Fluid Levels and Leaks

Fluid levels - remove the master cylinder reservoir cover and inspect the fluid level in both chambers. Some reservoirs have both hot and cold fill level indications; make sure you use the correct level. Low fluid level in either chamber could be either the result of normal brake lining wear or it could indicate an external leak.

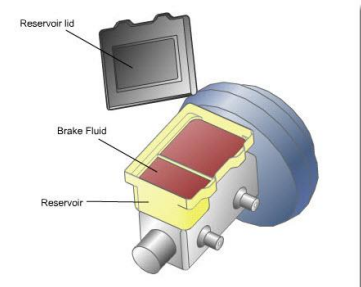

External leaks - visually check the master cylinder, calipers, and/or wheel cylinders for leaks. Fluid will be visible on the face of the power brake booster if the master cylinder is leaking from its rear seal.

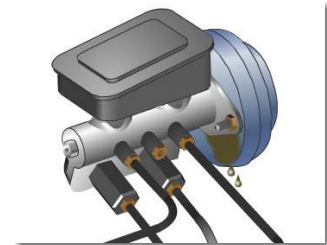

The bottom of the caliper will be damp with fluid if a disc brake is leaking.



The bottom of the backing plate will be damp with fluid if a wheel cylinder is leaking.

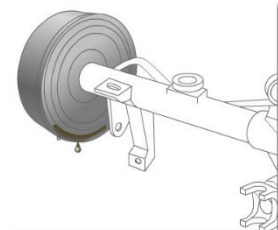

Note: Leaking calipers or wheel cylinders can coat the brake pads or shoes with brake fluid and cause complaints such as wheel lock up, brake squeal, pulling and ineffective braking.

CAUTION: Leaks should be repaired before driving any vehicle.

- Parking brake operation - With the key on and the engine off, engage the parking brake. The brake should apply with approximately half travel of the lever or pedal and the brake warning light should turn on. Deactivate the parking brake and it should release immediately. The lever or pedal should return to the release position and the warning light should turn off. Any problems with the engagement or release of the parking brake could indicate a binding linkage.
- Brake warning light - With the key on and engine off (parking brake disengaged), if a brake warning light comes on, with or without applying the service brakes, it could indicate a hydraulic failure in the system.

CAUTION: Repair the hydraulic system before driving the vehicle.

Detailed Visual Inspection

Component	Inspect for:	Corrective Action
Brake pipes and hoses	Leaks Crimps or restrictions	Repair or replace as necessary
Parking brake cables	Excessive Slack Corrosion that could prevent brake application or release	Clean, lubricate, adjust or replace as necessary
Parking brake operation	Proper operation Wheels rotate (parking brake engaged) Wheels cannot be rotated without excessive drag (parking brake disengaged)	Clean, lubricate, adjust or replace as necessary
Brake linings	Excessive wear	Replace
Brake hardware and hold-downs	Damage, wear or corrosion Missing Components	Replace
Brake Rotors	Wear (reduced thickness) Deep scoring or scratches Thickness variation Lateral runout Excessive heat checking	Replace Compare to specifications Machine or replace as indicated
Brake Drums	Wear (excessive diameter) Deep scoring or scratches Taper (bell mouth) Out of round Excessive heat checking	Compare to service limit specifications

Test Drive

A road test is the only reliable way to check the stopping abilities of the brake system. Road test all vehicles immediately after any brake work.

Procedure for preparing a vehicle for a road test

- Make sure the brake pedal is more than 1.5 in from the floorboard. The brake pedal should feel solid when depressed.
- If the vehicle is equipped with power brakes, start the engine while depressing the brake pedal. The pedal should move down slightly as the vacuum increases. Also make sure that other types of power-boosting devices within the brake system are operating correctly.
- Set the parking brake and try to move the vehicle. Make sure the parking brake can hold the vehicle. Release the parking brake and note the vehicle's freedom of movement. The vehicle should move freely.
- Let the vehicle begin to move very slowly and then apply the brakes. Make sure the brakes have adequate stopping power before driving the vehicle further.

Procedure for road testing the vehicle

Note: Conduct road tests in areas where there is little or no traffic.

- Accelerate to about 5 mph and gently apply the brake pedal.
- Make sure the brakes work effectively and smoothly. The vehicle should not pull in either direction during braking. There should be no unusual noise or brake pedal pulsation.
- Accelerate to about 30 mph and apply the brakes firmly.
- Make sure there is no wheel lockup, pulling, or unusual noise.

CAUTION: During a road test, never apply the brakes hard enough to lock up the wheels.

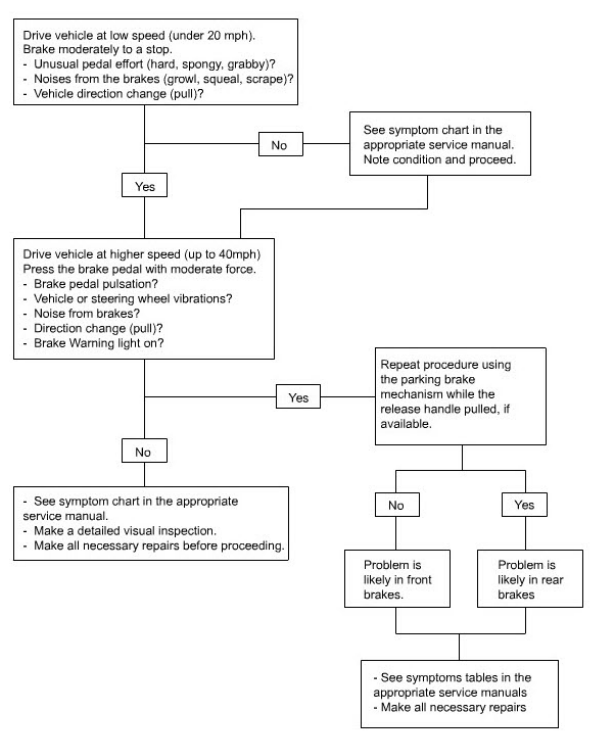

Asbestos

Safety Precautions for Dealing With Asbestos

At one time, brake lining material consisted mainly of asbestos. The federal government identified asbestos as a carcinogen (a cancer-causing substance) and prohibits its use in new vehicles. Asbestos can still be found in some older vehicles and in some replacement parts. The government agency OSHA (Occupational Safety and Health Administration) developed regulations for working with asbestos brake friction material. Mismanagement of asbestos in the shop is against federal law. Offenders can be fined, imprisoned, or both.

Asbestos brake lining material creates asbestos dust that must be captured by special equipment and disposed of according to federal regulations. The process of capturing and containing asbestos dust is called encapsulation. The automotive industry generally uses two methods of encapsulation: dry and wet.

The dry method of encapsulation

- The dry method requires placing a metal and plastic enclosure over the brake. This enclosure contains built-in rubber gloves with which the brake parts can be handled during cleaning.
- Using the built-in gloves, dust is blown from the brakes with an air hose (within the enclosure). The dust is contained in the enclosure and a special vacuum cleaner removes the dust. The brake dust is then collected in a plastic bag for disposal.

The wet method of encapsulation

- The wet method also requires placing a metal and plastic enclosure over the brake. As in the dry method, this enclosure contains built-in rubber gloves with which the brake parts can be handled during cleaning.
- Using the built-in gloves, a specially designed brake parts washer is used to spray the brake parts within the enclosure. The fluid washes the dust from the brake parts. A special vacuum cleaner moves the dust and fluid to a proper holding tank. The brake dust then collects in a plastic bag for disposal.

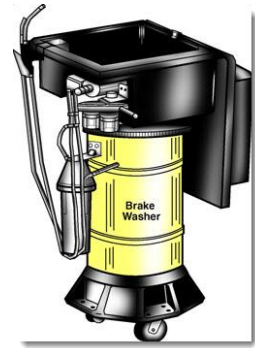

CAUTION:

- Federal law dictates precise procedures for disposing of encapsulated dust. Be sure to follow the federal procedures.
- Never use a household vacuum cleaner to remove asbestos from the enclosure. A household vacuum cleaner cannot adequately filter small asbestos particles.
- If encapsulating equipment is unavailable or in poor working order, do not perform brake or clutch work.

Vehicle Lifting

Safety Precautions for Lifting a Vehicle

To perform most brake work, it is necessary to lift the vehicle and work under the supported vehicle. When doing brake work, observe all safety rules regarding lifting a vehicle.

CAUTION:

- When lifting a vehicle, always use proper lifting equipment and observe all safety precautions.
- Never work under a vehicle that is supported by any type of jack or by blocks. Always use solid metal support stands or a lift that can support the entire vehicle by its frame.
- Never work under or around a vehicle supported by a bumper jack. Bumper jacks are especially dangerous.

Unit 2: Hydraulic System

Chapter 1: Introduction to the Hydraulic System

Hydraulic Principles

An important principle of hydraulics is **Pascal's law of hydraulics**. Blaise Pascal was a French philosopher, mathematician, and scientist. Pascal's law of hydraulics states that when pressure is applied to a fluid in an enclosed space, the fluid exerts the same pressure equally in all directions.

If two cylinders are filled with liquid and connected by a tube, pressure from one cylinder transfers to the other. Fluids are virtually incompressible. When put under pressure, fluid does not compress or produce any measurable friction. Pressure does not diminish when transferred through fluid.

A second hydraulic principle states that a relationship exists between:

- Force and piston area
- Piston travel and piston area

From the first principle, if a master cylinder generates 500 psi, it also transfers 500 psi to the pistons in each wheel cylinder (remember that fluid pressure remains constant).

In the second principle, when pressure from a one-square-inch master cylinder piston exerts 500 psi on a wheel cylinder piston, which also has one-square-inch surface area, the wheel cylinder piston transfers 500 pounds of force to the brake shoe (500 psi x 1 in. sq. = 500 lbs.).

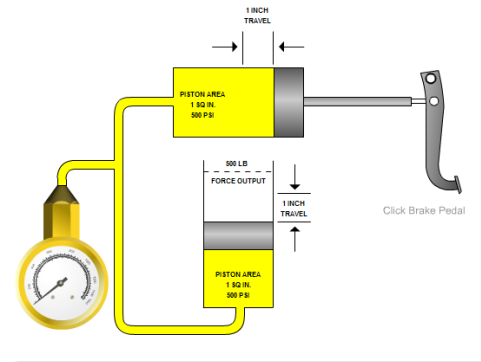

However, if the same one-square-inch master cylinder piston exerts 500 psi on a wheel cylinder piston that has a two-square-inch area, the wheel cylinder piston will transfer 1,000 pounds of force to the brake lining (500 psi x 2 in. sq. = 1,000 lbs.).

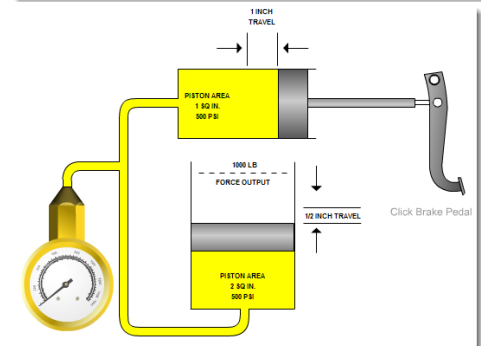

Additionally, different piston sizes not only affect the amount of brake force applied, they also determine the travel distance of the different pistons. For instance, if the one-square-inch master cylinder piston moves one inch, a one-square-inch wheel cylinder piston will also move one inch (with the same force). If that same one-square-inch master cylinder piston moves one inch, then a two-square-inch wheel cylinder piston (twice the size) will move just one-half inch (half the distance) but with twice the force.

Split Hydraulic Systems

Brakes are generally applied through force transmitted via a hydraulic system. The master cylinder converts brake pedal movement into hydraulic pressure to operate the brakes. A partial loss of brake pressure makes it difficult or even impossible to apply the brakes. Therefore, federal law requires that all vehicles have two separate and independent hydraulic systems. In this way, the failure of one system will not result in a complete brake loss even though braking will still be severely reduced. The two split systems used almost exclusively are:

- Diagonally split — used on most front wheel drive vehicles
- Front/rear split — used on most rear wheel drive vehicles

Diagonal Split Hydraulic System

In a **diagonal split hydraulic** system, the left-front and right-rear brakes (LF/RR) are connected to one channel of the master cylinder while the right-front and left-rear brakes (RF/LR) are connected to the other channel of the master cylinder. This system is typically installed on front wheel drive vehicles because they have a front-heavy weight distribution and approximately 70% of the braking occurs at the front brakes. As such, if one part of a diagonal system failed, the overall braking would only be reduced to 50% rather than to 30% if both front brakes were lost. Diagonally-split systems also use proportioning valves either in the master cylinder circuits or in the rear brake lines to maintain the proper front to rear pressure balance. Proportioning valves will be covered in a later section.

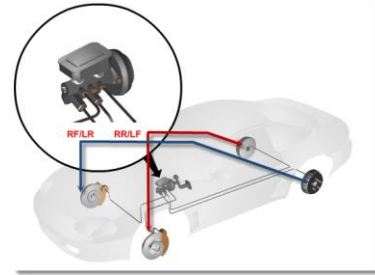

Front/Rear Split Hydraulic System

In a **front/rear split hydraulic system**, both front wheel brakes work together on one system (channel) while both rear wheel brakes work together on a separate system.

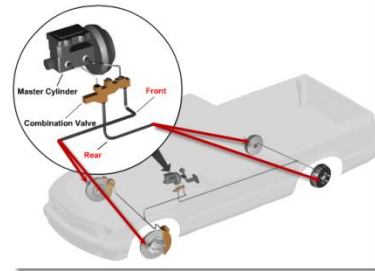

Master Cylinder

The function of a **master cylinder** is to convert mechanical force from the brake pedal, power booster and push rod into hydraulic pressure. Hydraulic pressure in this case is created by applying mechanical force to **brake fluid**.

Master cylinders contain pistons, piston seals, return springs and internal brake fluid ports. They also have a fluid reservoir that may either be an integral part of the unit or remotely mounted. The reservoir itself will have a removable cap with a rubber diaphragm seal that must be in good condition to seal properly. In addition, most reservoirs also have a low brake fluid level switch to alert the driver of a low fluid condition.



The Master Cylinder in Action

As you can see in the figure, there are two pistons (primary and secondary) and two springs inside the master cylinder. When the brake pedal is pressed, a push rod moves the primary piston forward which begins to build pressure in the primary chamber and lines. As the brake pedal is depressed further, the pressure continues to increase. Fluid pressure between the primary and secondary piston then forces the secondary piston forward and pressurizes the fluid in the secondary circuit. If the brakes are operating properly, the pressure will be the same in both circuits.

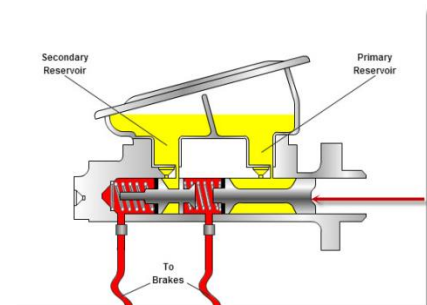

Brake Circuit Leak

If there is a leak in one of the brake circuits, that circuit will not be able to maintain pressure. The figure below shows what happens when one of the circuits develops a leak. In this example, the leak is in the primary circuit and the pressure between the primary and secondary pistons is lost. This pressure loss causes the primary piston to mechanically contact the secondary piston and the master cylinder now behaves as if it has only one piston. The secondary circuit will continue to function correctly, however the driver will have to press the pedal further to activate it. In addition, since only two wheels now have pressure, the braking power will be reduced. Refer to specific vehicle information for leak diagnostics and servicing procedures.

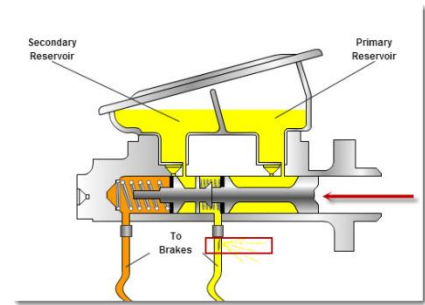

The following are basic leak type indications:

- External leaks - brake fluid can usually be seen running down the face of the power booster.
- Internal leaks - the brake pedal will usually fall away when foot pressure is applied.

Compensating Ports

Compensating ports are small holes that are located between the master cylinder reservoir and the front side, or pressure side, of the master cylinder pistons. When the master cylinder pistons are in the at-rest position (no braking), the piston seals uncover the compensating ports and open the passages between the reservoir and the wheel brake channel. The purpose of compensating ports is to allow for the normal expansion and contraction of brake fluid due to changes in temperature. They also assist in fluid return after brake release, which will be covered as part of the bypass port section.

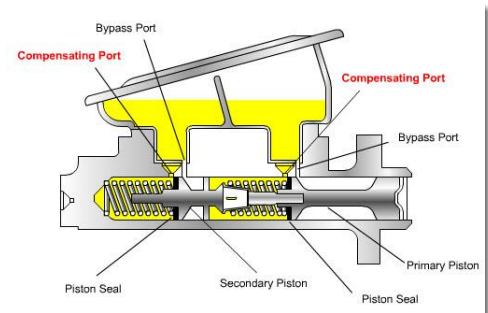

Note: When the brakes are released, the piston seals on both the primary and secondary pistons are located between the compensating port and the bypass port.

During braking, the piston seals close the compensating port passages to the reservoir, which prevents high pressure fluid from entering the reservoir.

Bypass Ports

The bypass ports, like the compensating ports, are passages that are open between the reservoir and the master cylinder chambers. However, the bypass ports are open to the low-pressure or back side of the pistons. The function of the bypass ports is to allow the master cylinder pistons to return to the at-rest position rapidly.

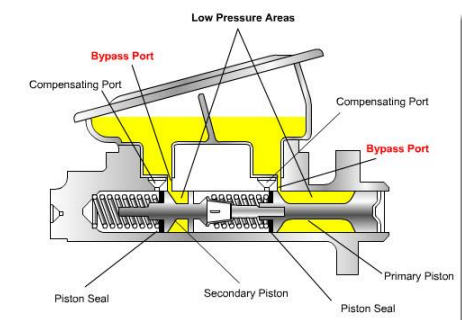

Brake Release

During brake release, the following occurs:

Strong springs in the master cylinder force the pistons back to the at-rest position faster than the brake fluid can return through the hydraulic channels. The pistons must return rapidly so they can be ready for another forward stroke, if necessary. This rapid piston return movement could create a vacuum in the master cylinder high pressure chambers, which would delay brake release. The bypass ports allow brake fluid from the reservoir to fill the low-pressure piston chambers. Brake fluid from the low pressure chambers then passes through holes in the pistons and bypasses the piston lip seals. The pistons can then return without any "dragging".

Since this "return action" causes additional fluid to be moved to the front of the piston, it results in an excess amount of fluid being present there, as even more fluid returns from the calipers and wheel cylinders. This excess fluid is easily returned to the reservoir through the now-open compensating ports.

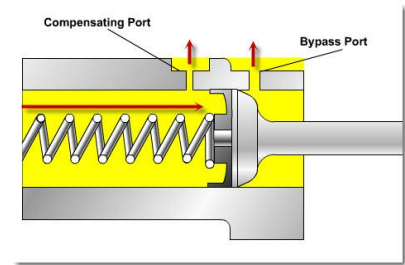

Note: "Piston dragging" can also occur if the seals are installed backward.

Residual Check Valve (drum brakes only)

On drum brake systems, residual check valves are also included in the master cylinder. Residual valves are located in the ports where the brake lines connect to the master cylinder. Their purpose is to maintain a small amount of residual pressure in the brake lines and wheel cylinders. That pressure is then used to hold the wheel cylinder cups tightly against the cylinder and prevent air from being pulled past the cylinder cups as the brakes are released. Residual valves are not used on disc brakes, as they would cause the disc brake pads to drag upon release.

Balance Control Systems

Many late model vehicles are equipped with front disc brakes and rear drum brakes and are generally heavier in the front than in the rear. As a result, different pressures are sometimes required between the front and rear to ensure even braking. These are some of the items to be aware of concerning this "braking differential":

- Disc brakes can apply at lower pressures than drum brakes.
- Metering valves are used to prevent the front disc brakes from applying before the rear drum brakes.
- During heavy brake application, the rear brakes can lock up, resulting in a skid and loss of vehicle control if the same hydraulic pressure is simultaneously applied to both the front disc and rear drum brakes.
- Proportioning valve(s) are used to prevent rear brake lockup by limiting hydraulic pressure to the rear brakes during heavy braking.

- The metering valve and the proportioning valve are often housed in a single unit, called a combination valve, in many rear-wheel-drive vehicles equipped with front disc and rear drum brakes.
- Most vehicles are equipped with some form of pressure differential valve and switch which will activate a dashboard warning light if pressure is lost in either of the hydraulic channels. This switch is typically located in a combination valve or on the master cylinder.

Metering Valve

Rear drum brake shoes must move a greater distance to apply as compared to disc brake pads. If the same pressure were applied to both the front disc and rear drum brakes at the same time, the front discs would "catch" much sooner than the rears and cause the vehicle to be thrown forward. **Metering valves** compensate by blocking fluid pressure to the front disc brakes until the rear shoes make contact with the drums.

As the brakes are first applied, fluid pressure rises above a calibrated value (approximately 25 psi) which closes the metering valve stem and blocks the fluid pressure from reaching the front disc brakes. However, fluid pressure is still applied to the rear brakes, which move the shoes out to contact the drums. Once the shoes begin to contact the drums, the pressure in the rear brake system starts to rise dramatically.

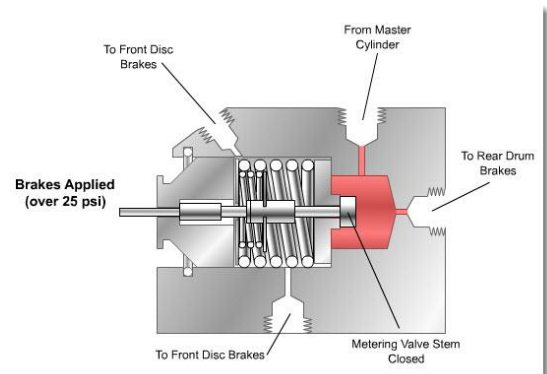

After the pressure reaches a second calibrated value (about 100 psi) the metering valve opens and begins to apply the front disc brakes.

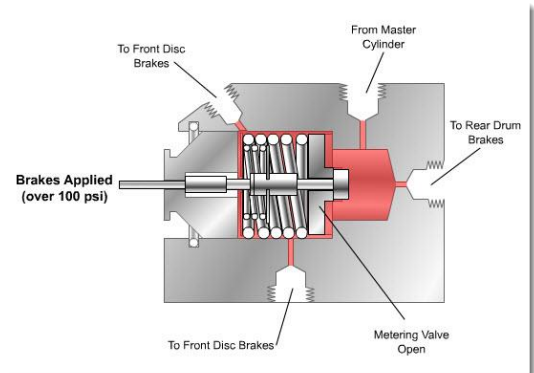

As the brakes are released and the system pressure again drops below 25 psi, the valve stem reopens to allow fluid to return to the master cylinder.

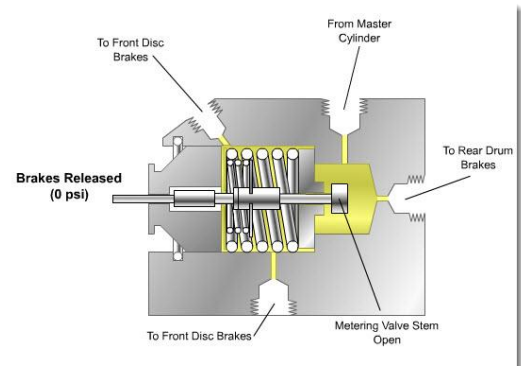

Notice also in the figures that there is a difference between the valve stem and the valve itself. Each is operated by a separate spring and has a separate function.

Note: The two pressure points (25 psi & 100 psi in this example) are calibrated based on the size and weight of a particular vehicle. Metering valves are not universally interchangeable even though they may appear to be identical.

Proportioning Valve

Under heavy braking conditions, rear drum brakes are more susceptible to premature lock-up than the front disc brakes. Part of the reason is that rapid braking forces tend to pitch the vehicle forward which, reduces the weight on the rear wheels increasing the likelihood of lock-up. **Proportioning valves** are used in the rear hydraulic circuit(s) to help prevent premature lock-up. During normal braking, or when the brakes are first applied, the proportioning valve is open and has no effect. Fluid enters the valve through the end with the smaller piston area, passes through the small bore, and exits to the rear brakes.

Notice that the outlet end of the valve piston has a larger surface area than the inlet end of the valve. When fluid pressure rises rapidly in the valve (under hard braking), it exerts a greater force on the larger outlet piston than it does on the smaller inlet piston. This action moves the valve, against spring pressure, toward the inlet and closes the center valve. With the valve closed, pressure to the rear brakes is blocked.

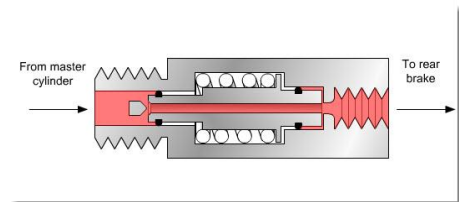

As the inlet pressure from the master cylinder continues to rise, it becomes high enough to overcome the larger outlet piston and the valve opens allowing additional pressure to the rear brakes. The reopening of the valve increases pressure on the outlet side that closes the valve. This cycle is repeated several times a second and keeps the pressure to the rear brakes proportionately less than the pressure to the front disc brakes. The proportional cycling action therefore makes for more positive braking under adverse conditions.

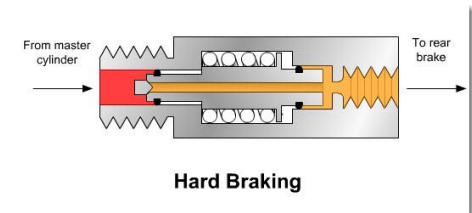

Pressure Differential Valve (Switch)

Pressure differential valves are spring-loaded plunger valves that are used to turn on dashboard warning lights if hydraulic pressure is lost in either channel of a hydraulic brake system. Once the pressure loss problem is repaired, some valves will automatically reset themselves while others must be bled to reset. Refer to the appropriate service material for the applicable procedure.

The metering valve, proportioning valve and the pressure differential switch are sometimes housed together in a single unit called a **combination valve**. Combination valves are used only on front/rear split brake systems.

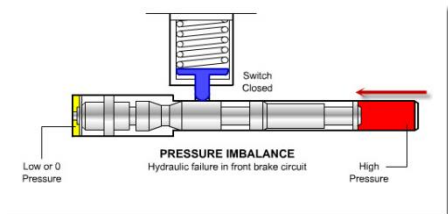

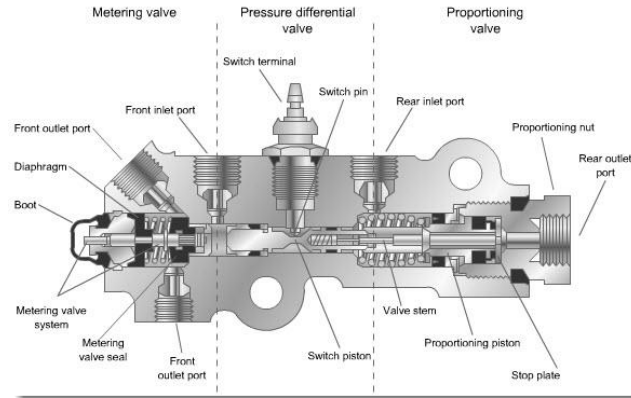

Chapter 2: Servicing the Hydraulic System

Servicing Brake System Switches and Valves

Inspecting and testing hydraulic brake switches and brake valves

CAUTION:

- Never attempt to repair a pressure differential valve, metering valve, proportioning valve, or combination valve. If the valves are defective, replace them.
- Always check and refill the master cylinder after testing or servicing the hydraulic system components.
- Always make sure the hydraulic system is free from air after testing or servicing the hydraulic system components.

Procedure for testing the differential pressure valve

1. Make sure the brake warning light and circuit are functioning before testing the valve. Use the procedure outlined below.

- Disconnect the differential pressure valve wire and ground it. Use a jumper wire, if necessary.
- Turn the ignition switch to the on position. The brake warning light should come on.
- If the light fails to come on, then the circuit or bulb may be defective.
- Replace the bulb and repair the circuit.
- Retest the circuit to ensure it is operational.

2. After ensuring that the brake warning light circuit is operational, test the differential pressure valve switch circuit. Use the procedure outlined below.

- Make sure the differential pressure valve switch is properly connected to the circuit.
- **Note:** The differential pressure valve switch is an integral part of the valve and cannot be separated.
- Connect a bleeder hose to one of the rear-wheel bleeder valves. Put the other end of the bleeder hose in a container of clean brake fluid.
- Open the bleeder valve.
- Have an assistant apply moderate pressure to the brake pedal and observe the brake warning light.

- **Note:** Apply a reasonable amount of pressure to the brake pedal. If too little pressure is applied, the valve does not shift and the light stays on. If too much pressure is applied, the valve moves too far and must be recentered by applying pressure to the other system.
 - If the brake warning light comes on, the switch and valve are functioning normally.
 - If the brake warning light does not come on and the light circuit is operational, replace the differential pressure valve.
 - Reconnect bleeder hoses and once again apply pressure to the brake pedal to ensure that the brake warning light comes on.
 - **Note:** If the differential pressure valve is defective, it may be simpler to replace the valve and performance test the system than to perform the test procedure described above.
3. If the differential pressure valve has no centering springs, reset the switch after activating the brake warning light.
- Install a bleeder hose to the rear-wheel bleeder valve of the hydraulic system that was not involved in the first differential pressure valve test.
 - Immerse the other end of the bleeder hose in a container of clean brake fluid.
 - Open the bleeder valve.
 - Have an assistant apply pressure to the brake pedal while watching the brake warning light. When the warning light goes off, center the valve.
 - **Note:** Relatively heavy brake application is required to center the piston.
 - As soon as the light goes out, close the valve.

Procedure for testing the metering valve

- Inspect the metering valve for damage and leaks. Make sure the valve's mounting is sufficiently tight.
- Tighten the valve's mounting if it is loose.
- Metering valves are not adjustable or repairable. If the valve leaks or is damaged, replace it.
- Install a high-pressure hydraulic gauge set to the line leading to the rear brakes and to the line leading from the master cylinder outlet port (which in turn leads from the rear brake side of the master cylinder to the metering valve).
- **CAUTION:** Gauge sets used to test the metering valves must be capable of withstanding pressure up to 1,500 pounds per square inch (psi).
- After connecting the gauge set, apply heavy pressure to the brake system and compare the readings of the two gauges with the manufacturer's specifications. If the reading does not meet the specifications, replace the valve.

Procedure for testing the proportioning valve

Inspect the proportioning valve for damage and leaks. Proportioning valves are not repairable. If the valve leaks or is damaged, replace it. Mount the new proportioning valve in the same position as the old valve. Alteration in suspension height interferes with the proportioning valve's performance. After such maintenance or if the suspension height is altered due to wear, check and adjust the proportioning valve linkage according to the procedure outlined below.

Note: Do not add equipment such as helper springs, air shocks, or trailer towing packages to vehicles using proportioning valves. Such modifications may stiffen the rear suspension and interfere with the valve's performance.

- Make sure the suspension is at rest and the vehicle is carrying its normal load. Also ensure that the fuel tank is full, the spare tire and normal tools are in the trunk, and the rear seat is vacant.
- Adjust the bracket to remove all slack from the linkage and spring that connect the valve to the suspension.
- Install a high-pressure hydraulic gauge set to the line leading to the rear brakes and to the line leading from the master cylinder outlet port (which in turn leads from the rear brake side of the master cylinder to the proportioning valve).

CAUTION: Gauge sets used to test proportioning valves must be able to withstand pressure up to 1,500 psi.

After connecting the gauge set, apply heavy pressure to the brake system and compare the two gauge readings with the manufacturer's specifications. If the reading does not meet the specifications, replace the valve.



Note: If the proportioning valve is defective, it may be simpler to replace the valve and performance test the system than to perform the above test procedure.

The combination valve includes either two or three of the valves mentioned above (differential pressure valve, metering valve, and proportioning valve). Use the same procedure for testing the valves separately when testing the valves individually.

Note: If any valve within the combination valve is defective, it may be simpler to replace the combination valve and performance test the system than to test the individual valves.

Testing the Brake Warning Light

The brake warning light, located on the vehicle's dash, indicates that either a hydraulic brake system has lost pressure or the parking brake is on.

CAUTION: The brake warning light may come on due to a faulty switch or a problem with the parking brake. If the brake warning light comes on, make sure that both the brake systems have adequate pressure and are working properly before inspecting the brake warning light switch or parking brake.

Note: The brake warning light is usually powered by the accessory circuit and activates only when the ignition switch is on. The brake light switch controls this warning light by grounding the circuit.

Procedure for testing the brake warning light

- Check the brake warning light. Turn the ignition key to the on position and observe the brake warning light. If the light is off, the system is functioning normally. If the light is on, continue the diagnosis.
- Locate the brake warning light switch. Make sure the brake linkage is properly deactivating the brake warning light switch.
- If the parking brake linkage is properly deactivating the switch, move the switch's deactivating device with a small screwdriver. If the light does not go off, unplug the switch.
- If unplugging the switch causes the light to go off, replace the switch.
- Locate and replace the differential pressure valve (or combination valve) and brake light switch.
- If the light remains on, check for shorts in the wiring between the switch and the valve.

Note: To locate the differential pressure valve, follow the brake line leading from the master cylinder. Remember that on most vehicles the differential pressure valve is contained within the combination valve. In order to replace the differential pressure valve, replace the entire valve.

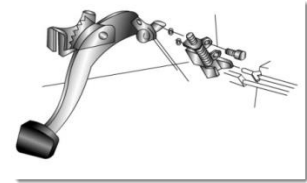

Servicing the Master Cylinder

Inspecting the master cylinder

Note: The following are general procedures. Always consult the proper service information when inspecting the master cylinder.

- Check the master cylinder fluid.

Procedure for checking the master cylinder for external leaks

- Thoroughly clean and dry the exterior of the master cylinder. Also clean and dry the brake lines and fittings near the cylinder.
- Pump the brake pedal at least 10 times and then look for signs of leakage around the brake lines, cap, or power booster mounting bracket, if present.
- **Note:** In manual brake systems, external leaks at the input rod end of the master cylinder deposit brake fluid on the passenger compartment floor. In power brake systems, external leaks at the input rod end of the master cylinder deposit brake fluid on the power booster. Therefore the passenger compartment floor and power booster should be checked for traces of brake fluid.

Procedure for checking the master cylinder for internal leaks

- When the vehicle is stopped, hold down the brake pedal. Note if the pedal slowly loses firmness.
- If the pedal regains firmness after it is released and pressed down again, there may be an internal leak in the master cylinder.
- **Note:** A soft or spongy pedal may indicate a leak in the master cylinder.

- The loss of firmness may also indicate an external leak in the brake lines or brake actuators.
- To confirm the possibility of an internal master cylinder leak, have an assistant hold down the brake pedal and check for external leaks at the wheel cylinders, calipers, brake lines, and fittings. If no leaks are found, the loss of firmness may indicate an internal leak in the master cylinder.

Procedure for checking the operation of the master cylinder

- Place the reservoir cap loosely on the master cylinder.
- Have an assistant quickly pump the brake pedal at least 10 times.
- Have the assistant hold down the pedal with medium pressure (25 lb to 35 lb).
- Remove the cap from the reservoir and have the assistant release the brake pedal. The reservoir fluid should gush up noticeably (about 1/4 in) from the reservoir. If the fluid does not gush, air may be present in the system; therefore, bleed the system.

CAUTION: Keep face away from the master cylinder.

Note: If fluid still does not gush after the system has been bled, either the master cylinder vent port or compensating port is plugged, or the brakes are not releasing.

Removing, Bench Bleeding, and Replacing the Master Cylinder

CAUTION:

- Always check and refill the master cylinder after testing or servicing the hydraulic system components.
- Always make sure the hydraulic system is free from air after testing or servicing the hydraulic system components.

Removing the master cylinder

- Disconnect the hydraulic tubing from the master cylinder.
- Remove the bolts that hold the master cylinder to the brake booster and remove the cylinder from the vehicle.

Note: On some manual brake systems, the master cylinder push rod is secured to the piston with a locking device. On these cylinders, the push rod is disconnected from the brake pedal and removed with the master cylinder. The push rod is removed from the piston on the workbench.

- Remove the cylinder cover(s) and drain as much fluid from the cylinder as possible.

Some cylinders have reservoirs that are mounted in a remote location and connect to the master cylinder by hoses. These reservoirs can be disconnected from the master cylinder and remain in the vehicle. Some reservoirs have only one chamber that contains a separator to feed both hydraulic systems. Other systems have separate reservoirs for each hydraulic system.

Bench bleeding

Bench bleed all master cylinders immediately before installation. Air easily enters dual master cylinders. Normal bleeding does not always purge air.

Procedure for bench bleeding the master cylinder:

- Connect two short pieces of brake line to the master cylinder outlet ports. Direct the lines into the reservoirs.
- Fill all reservoirs with clean brake fluid so that the ends of the return lines are submerged.
- Using a short dowel or other such tool, slowly pump the master cylinder piston until the bubbles stop forming in the reservoir.

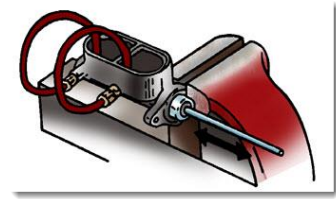

To reinstall the master cylinder, simply reverse the removal procedure. Bleed the brakes and add new brake fluid to the system. Check and adjust the push rod, if necessary, and test drive the vehicle.

Inspecting and Adjusting Brake Pedal Free Height and Travel

Procedure for determining the brake pedal free height and travel

CAUTION: Make sure to set and properly adjust the parking brake before performing this procedure.

- Push a sharp metal probe through the passenger compartment carpeting under the brake pedal. Make sure the probe contacts the floorboard metal.
- Measure the distance between the sharp end of the probe contacting the floorboard metal and the point where the probe touches the top of the brake pedal pad. This measurement is the brake pedal free height.

Note: On most vehicles, the brake pedal free height should be between 7 in and 8 in. Incorrect free height indicates worn, bent, or improperly installed parts. Free height is not always adjustable.

- If servicing a power brake system, start the vehicle's engine. If servicing a manual brake system, leave the vehicle's engine off.
- Apply about 25 lbs. of pressure to the brake pedal. While applying pressure, once again measure the distance between the sharp end of the probe contacting the floorboard metal and the point where the probe touches the top of the brake pedal pad.
- The difference between the first and second measurements is called pedal travel. On manual brakes, the pedal travel should be between 3.5 in and 4.5 in. On power brakes, the pedal travel should be between 2 in and 3 in.

Procedure for adjusting brake pedal free travel

Excessive brake pedal travel may indicate a problem with the brake pedal push rod. A spongy pedal may indicate that air is trapped in the system. When correcting excessive brake pedal travel on these systems, ensure that the master cylinder piston returns to its release position when the brakes are disengaged. There should be a small amount of clearance between the push rod and the piston when the brakes are not applied.

Procedure for correcting excessive brake pedal travel on systems with adjustable push rods:

- Ensure that when the driver disengages the brakes, the master cylinder piston is at the proper release position.
- Ensure that when the driver disengages the brakes, the brake pedal is at its proper release position.

- Check the pedal free height and correct it if required.
- With the push rod installed and the master cylinder piston and brake pedal at their proper release positions, adjust the rod length so there is a slight clearance between the end of the push rod and the piston.

Brake pedal checks

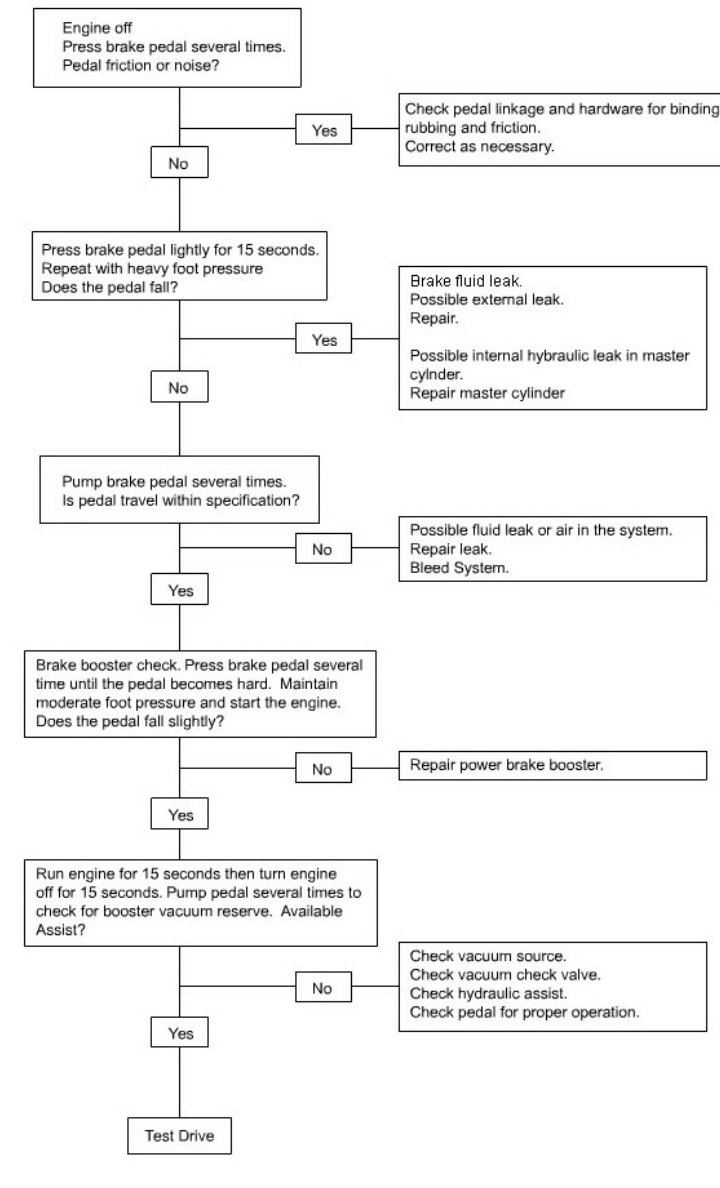

Brake Fluid

The specifications for all automotive brake fluids are defined by the Federal Motor Vehicle Safety Standards and are assigned Department of Transportation (DOT) numbers. These specifications list the qualities that brake fluid must have such as:

- Free flowing at low and high temperatures
- A boiling point over 400 degrees F. (204 degrees C.)
- Low freezing point
- Non-corrosive to metal or rubber brake parts
- Ability to lubricate metal and rubber parts
- Hygroscopic - Ability to absorb moisture that enters the hydraulic system

DOT 3 and DOT 4 are polyalkylene-glyco-ether mixtures. All domestic and most import car manufacturers specify and require DOT 3 brake fluid (some imports require DOT 4 as it has a higher boiling point). Precautions must always be observed when working with brake fluids:

- Brake fluid is toxic to the human body.
- Brake fluid can damage painted surfaces.
- Brake fluid contaminated with moisture, dirt, petroleum or other foreign material will damage the hydraulic system internally.
- Only denatured alcohol or other approved cleaners should be used when cleaning brake hydraulic parts.
- Use only fresh, clean brake fluid (never reuse old brake fluid).
- Never mix brake fluids with any other fluids, including other types of brake fluid (e.g. DOT 3 and DOT 4).

Storing Brake Fluid

- In order to prevent contamination, brake fluid must not be exposed to the open air. Brake fluid containers must be tightly capped and clearly marked.
- Do not punch air holes in brake fluid containers.
- Do not store brake fluid in extreme heat or cold.
- Do not store more fluid than can be used in a month. Brake fluid can be easily contaminated with moisture if stored for long periods.

- CAUTION:**
- Moisture is very harmful to brake fluid; it can reduce brake fluid's boiling point, which can have grave consequences.
 - Brake fluid is toxic to both humans and animals. Never store brake fluid in a manner that could allow it to be mistaken for food or drink.

Handling Brake Fluid

- CAUTION:**
- Ingesting brake fluid causes sickness or death. If brake fluid contacts the eyes, blindness may result. Avoid contact between brake fluid and skin.
 - Brake fluid damages automotive paint and other finishes.
- Never reuse brake fluid.

- Do not allow used brake fluid to collect in large amounts.
- Immediately and safely dispose of brake fluid that is contaminated or even suspected of being contaminated.

Selecting Brake Fluid

Always choose high-quality, DOT-approved brake fluid. Avoid "bargain brand" brake fluids. Never skimp or cut corners when servicing the brake system. The brake fluid should meet or exceed the manufacturer's specifications.



DOT 3 and DOT 4 Brake Fluid



DOT 5 Brake Fluid

Procedure for Adding Brake Fluid

CAUTION: Follow the proper procedures when adding brake fluid to antilock brake systems to avoid injury to the technician and damage to the brake system.

- Park the vehicle on a level surface.
- Carefully clean all dirt from the master cylinder cover.
- Remove the master cylinder cover.
- Make sure the fluid in the reservoir is clear and clean. If the fluid has a rusty or milky appearance, drain, flush, and bleed the brake system.
- Add fluid to the system until the level is within 1/4 in of the top of the reservoir.
- Restore the shape of the cover diaphragm. It should have no holes and be in good condition. The diaphragm may have become soft as a result of contaminated fluid.
- Reinstall the cover.
- Check the vehicle to ensure that no brake fluid has spilled or was thrown on painted surfaces. Use soap and water to clean brake fluid off any painted surfaces.

Contaminated brake fluid

Contaminated or poor-quality brake fluid may cause the brake pedal to feel soft or spongy after hard braking. Check for the following problems that may cause spongy or soft pedal.

- Check for soft spots in the brake hoses. Soft spots can cause the hoses to swell under pressure. If soft spots are found, replace all hoses and check for contaminated fluid.
- Check for air in the hydraulic system. If air is found, bleed the system.

Note: If the brake fluid is contaminated, drain, flush, and refill the brake system and replace all rubber parts.

Brake Bleeding

Brake Bleeding Fundamentals

Any time a brake hydraulic system is opened to the atmosphere for repairs or due to a leak, the system must be bled to remove the air. The two most commonly used methods for bleeding brakes are:

- Pressure bleeding
- Manual bleeding

Master Cylinder Bleeding

It is always a good idea to bench bleed a master cylinder after servicing and before installing/reinstalling it on the vehicle. One method for bench bleeding a master cylinder requires attaching two brake lines to the master cylinder and directing them back into the reservoir. Fill the reservoir(s) with clean DOT brake fluid and slowly push the master cylinder pistons in several times until air bubbles are no longer seen. This procedure will save time and fluid when bleeding the hydraulic system after the master cylinder has been reinstalled.

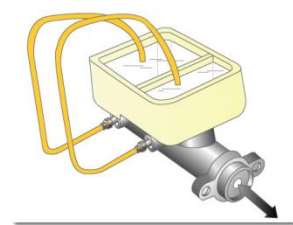

Bench Bleeding a Master Cylinder

Manual Bleeding and Vacuum Bleeding

The manual brake bleeding process requires two technicians and the fluid level in the master cylinder must be checked often. Technician # 1 begins the procedure by pressing the brake pedal to build up fluid pressure. Technician # 1 then continues to hold a steady pressure on the brake pedal while Technician # 2 opens the bleeder valve and observes as fluid and air bubbles are expelled. The brake pedal will go to the floor and Technician # 1 will continue to hold steady pressure on the brake pedal until Technician # 2 closes the bleeder valve. This process is repeated until all the air has been expelled. Repeat the process for all four wheels. Check and refill the master cylinder between wheels and when the procedure is completed. Test the brakes to make sure the pedal is firm before driving the vehicle.

- Note:**
- Do not allow the master cylinder to run out of fluid, or air will be introduced into the system.
 - A valve depressor tool may be required to bleed the front disc brake calipers on vehicles equipped with a metering valve.

Bleeding Order

The proper bleeding order depends on the vehicle. If it is a front-rear split system, start with one of the rear brakes (it really doesn't matter which but most people start with the right-rear), then move to the other rear brake. That will completely bleed that system (the rears). Then bleed the front brakes. Again the order is really unimportant. If the vehicle has a diagonally split system you may begin wherever you like - but whichever you do first, the opposite brake must be next to prevent the possibility of aeration. If the right-rear is first, the left-front must be next. If you start with the right-front, then the left-rear is second. Most seasoned technicians will typically go from right-rear to left-front then from left-rear to right-front. That is usually a good idea since a consistent procedure helps to avoid errors.

A note before we finish this section: because of the nature of some antilock brake systems, certain vehicles will use a specific bleeding order to help ensure that all of the air is removed from that unit. If that is the case, follow the manufacturer's instructions.

Procedure for manually bleeding the brake system

Note: This is a general procedure. Consult service information before beginning. This procedure does not apply to antilock brake systems.

- Use proper lifting equipment to raise the vehicle.

CAUTION: When lifting a vehicle, always use proper lifting equipment and observe all safety precautions.

- Make sure that all bleeder valves are free and clean. Remove and clean the screws as necessary.
- Add clean, new brake fluid to a clear glass jar until it is half full.
- Install a six-point boxed end bleeder wrench on the bleeder valve.
- Connect one end of a transparent bleeder hose to the bleeder valve. Make sure the other end of the hose hangs in the brake fluid jar.
- Override the metering valve, if included in the system, by applying a metering valve tool to activate the valve's plunger.
- Open the bleeder valve about one-half turn.
- Have an assistant depress the brake pedal slowly to the floor and hold it there. While the pedal is depressed, observe the fluid flowing into the jar.
- Close the bleeder valve.

Note: To prevent additional air from getting sucked into the brake system, close the valve completely before releasing the brake pedal.

- Release the brake pedal.
- Repeatedly press the pedal to the floor until the fluid that releases into the jar is clear and free of air bubbles. Remember to close the valve completely each time the brake pedal is released.
- Once the released fluid is clean, go to the next wheel.
- Repeat the procedure until the brake system is completely bled.

Note: Make sure that the master cylinder remains full throughout the bleeding procedure. If at any point the cylinder runs dry, start the procedure again.

- Remove the metering valve tool, if used.
- Lower the vehicle.
- Top the fluid level in the master cylinder; check the brake system for leaks.
- Press the brake pedal to the floor. If the pedal feels spongy or soft, repeat the entire process.

Procedure for vacuum bleeding the brakes

Note: This is a general procedure. Consult service information before beginning. This procedure does not apply to antilock brake systems. Vacuum bleeding requires a piece of equipment called a brake vacuum bleeder, which is essentially a pump. The brake vacuum bleeder uses compressed air as a power source. Read the manual accompanying the vacuum bleeder to be used.



- Use proper lifting equipment to raise the vehicle.

CAUTION: When lifting a vehicle, always use proper lifting equipment and observe all safety precautions.

- Make sure all brake bleeder valves are free and clean. Remove and clean the valves as necessary.
- Connect the compressed air supply to the vacuum bleeder. Turn on the compressed air.
- Connect a transparent bleeder hose from the vacuum bleeder to the first bleeder screw in the bleeding sequence.
- Override the metering valve, if included in the system, by applying a metering valve tool to activate the valve's plunger.
- Open the bleeder valve and observe the fluid as it runs down the clear plastic hose. As soon as the fluid runs clear, close the bleeder valve.



Note: Make sure that the master cylinder remains full throughout the bleeding procedure. If at any point the cylinder runs dry, start the procedure again.

- Repeat the bleeding procedure on all the other brakes. Make sure to bleed the brakes in the proper sequence.
- Remove the bleeding equipment and check the brake system for leaks.
- Remove the metering valve tool, if used.
- Lower the vehicle and press the pedal to the floor. If the pedal feels soft or spongy, repeat the entire bleeding procedure.

Pressure Bleeding

A **pressure bleeder** is a special tank that is divided into two chambers by a rubber diaphragm. The upper chamber is filled with clean fresh DOT 3 brake fluid while the lower chamber is pressurized with air. The rubber diaphragm keeps the brake fluid separated from the air. **Pressure bleeding** is often the preferred method for bleeding brakes since one person can do the job alone and the master cylinder does not have to be repeatedly refilled during the process.

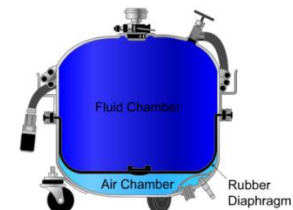

A Typical Brake Pressure Bleeder

Pressure bleeders are attached to the master cylinder with a hose and a special adapter. The special adapter seals the pressure bleeder to the master cylinder to prevent fluid and air leaking into or out of the system.

To pressure bleed a brake system, fill the pressure bleeder with clean DOT 3 brake fluid and charge the air reservoir with 15 to 20 psi (105 - 140 kPa) of air. Fill the master cylinder reservoir to the proper level, usually about one quarter (1/4) inch from the top. Install the bleeder adapter to the master cylinder reservoir, attach the supply hose from the pressure bleeder to the adapter, and open the supply valve.

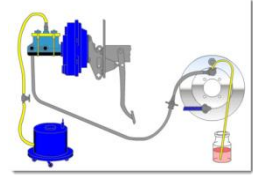

Pressure bleeder with hose and master cylinder adapter

Attach a bleeder hose to the wheel cylinder bleeder valve and extend the end of the hose into a clear glass container partially filled with DOT 3 brake fluid. Open the bleeder valve and any air trapped in the system can be seen as bubbles escaping from the bleeder hose. Close the bleeder valve after all air bubbles have been expelled. Repeat the bleeding process for all four wheels.

Remove the pressure bleeding equipment and fill the master cylinder to the proper level. Test the brakes to make sure the pedal is firm before driving the vehicle.

Note: A valve depressor tool may be required to bleed the front disc brake calipers on vehicles equipped with a metering valve.

Procedure for pressure bleeding the brake system

Note: This is a general procedure. Consult service information before beginning. This procedure does not apply to antilock brake systems.

Different types of pressure bleeders are available. Read the manual accompanying the pressure bleeder to be used. Using the directions in the pressure bleeder manual, charge the pressure bleeder with clean brake fluid and compressed air.



- CAUTION:**
- Do not overcharge the pressure bleeder.
 - When lifting a vehicle, always use proper lifting equipment and observe all safety precautions.
- Use proper lifting equipment to raise the vehicle.
 - Make sure that all bleeder valves are free and clean. Remove and clean the screws as necessary.
 - Add clean, new brake fluid to a clear glass jar until it is half full.
 - Connect the pressure bleeder to the master cylinder using the proper adapter fitting.
 - Override the metering valve, if included in the system, by applying a metering valve tool to activate the valve's plunger.
 - Open the valve in the pressure bleeder hose.
 - Install a six-point bleeder wrench on the first bleeder valve in sequence. Next, connect a transparent bleeder hose to the valve and allow the open end of the hose to hang immersed in the brake fluid jar.
 - Open the bleeder valve one-half turn or more and observe the fluid as it runs into the jar. Watch for air bubbles and other signs of contamination in the fluid. When clear fluid exits the hose, close the valve.

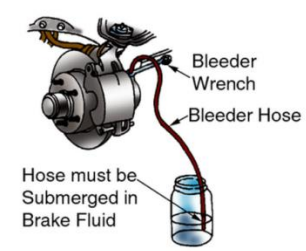

- **Note:** Make sure that the master cylinder remains full throughout the bleeding procedure. If at any point the cylinder runs dry, start the procedure again.
- Repeat the above procedure until the brake system is completely bled. Make sure to bleed the brakes in the proper sequence.
- Lower the vehicle and close the valve in the pressure bleeder hose.
- Remove the metering valve tool, if used.
- Check the brake system for leaks.
- Press the brake pedal to the floor. If the pedal feels spongy or soft, repeat the entire process.

Brake Lines and Hoses

Brake lines and hoses transfer fluid pressure from the master cylinder to the brake calipers and wheel cylinders. On some vehicles, this pressure can exceed 1000 psi. The brake hoses (the shorter rubber-covered sections that connect at the wheels) must also handle this duty while maintaining a high degree of flexibility. Only double-walled steel brake tubing is approved for use in brake lines.

CAUTION: Never use copper tubing as a replacement. It cannot withstand the high pressure or the vibration to which brake lines are exposed. Fluid leakage and system failure can result.

Brake Lines

When replacing a brake line, it is advisable to purchase a preformed OEM replacement, as they are of the correct length, bend, and strength to handle the system demands. It can also be more cost-effective, since bending and flaring brake lines can be quite time consuming.

In addition to OEM replacements, aftermarket lines are also available in various lengths and diameters. Many are also pre-flared and have flare nuts installed. Aftermarket bulk brake line is also available which can be cut to length and flared as needed. Keep in mind that this is a job to be performed only by those with the requisite tools and skills. Additionally, care must always be exercised when bending any brake line so as to not kink and weaken the line.

All vehicles utilize one of two methods of brake line connection flaring and each requires its own special tools and flare nuts. They are:

- ISO (International Standards Organization) flare
- Double flare

ISO and inverted double flares are distinguishable by the shape of the flare

Some fittings use a hollow bolt to carry brake fluid. These fittings are called banjo fittings and banjo bolts. Use only replacement fittings that are designed for the brake system.

CAUTION: Never cut a brake line in order to repair it. Always replace - never repair - brake lines.

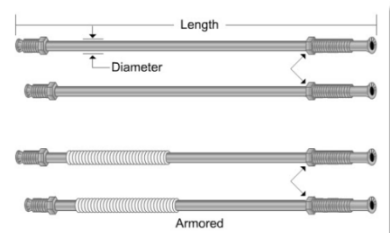

Brake tubing with flared ends and flare nuts installed

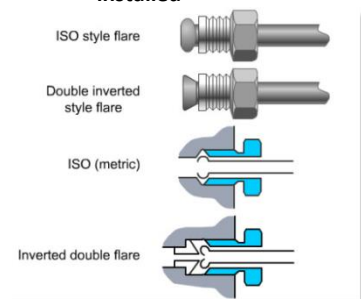

Brake Hoses

Automotive brake hoses are designed to distribute high pressure brake fluid to the wheel brakes. They must also allow for movement of the suspension and the motion of the front wheels. These forces are substantial and can weaken the hoses over time. When performing brake service, always remember to:

- Inspect the hoses for damage, kinks or ballooning
- Inspect hoses for proper routing
- Never hang a caliper from a rubber brake hose
- Replace the copper sealing washers when replacing brake hoses

Defective or damaged hoses can balloon or swell, which will store brake fluid pressure and cause the vehicle to pull during braking or give a low pedal concern. A blocked, restricted, or kinked brake hose can also cause the vehicle to pull during braking. In this case the pull will be to the opposite direction of the problem component. That means that a left-front hose that is blocked, restricted, or kinked would cause a pull to the right and a right-front hose failure would cause a pull to the left during braking.

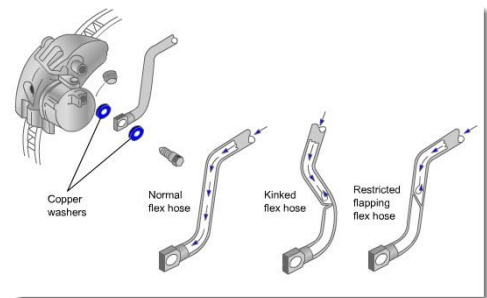

Brake hoses and failure modes

Inspecting and replacing brake lines and hoses

Inspect all metal brake lines for cracks, dents, corrosion, and leakage around fittings. Replace any damaged lines. Corrosion can "freeze" the flare nut to the brake line. Apply penetrating oil to the nut before attempting to free it. If the nut cannot easily be freed, cut the line, remove the frozen fitting, and replace the entire line.

- CAUTION:**
- Always check and refill the master cylinder after testing or servicing the hydraulic system components.
 - Always make sure the hydraulic system is free from air after testing or servicing the hydraulic system components.
 - Do not attempt to patch or add sections to the brake lines. If a line is damaged, replace the whole line.

Note: When replacing the brake lines, be sure to use two wrenches on the flare nuts to avoid damaging the fittings.

Repair any leaks at a fitting or a flare.

- Disconnect the fitting.
- Cut off the leaking flare.
- Reflare the fitting (double flare and ISO types).
- Reconnect the fitting.
- Check for more leakage.
- Make sure all replacement lines and fittings are clear of any moving suspension components.

Inspect all brake hoses for deterioration, chafing, swelling, cracking, or twisting. Also inspect for cuts.

CAUTION: Always replace damaged or worn brake hoses. Do not attempt to repair them.

- Replace any hose showing signs of leaking.
- Replace hoses that are oil soaked, soft, or spongy.
- Replace hoses that have deeply cracked covers.
- If the brake on one wheel drags (does not release), it may be necessary to replace the brake hose on that wheel. Sometimes an internal failure in a brake hose can cause the brake to drag. Explore all other possible causes of dragging before replacing the hose.
- Brake hoses are usually fastened to the vehicle chassis with a sheet metal clip to prevent chafing. Disconnect the flare nut from the hose before removing the sheet metal clip.
- Make sure the replacement hoses are sufficiently long. Suspension movement or steering action should not stretch the hoses.

Unit 3: Drum Brakes

Chapter 1: Introduction to Drum Brakes

Drum Brakes

A drum brake unit consists of two brake shoes mounted on a stationary backing plate. When the brake pedal is pressed, a hydraulically activated wheel cylinder pushes the shoes out to contact a rotating drum which creates friction and slows the vehicle. As the pedal is released, return springs retract the shoes to their original position. The two most common types of drum brakes that we will deal with are **duo-servo** and **leading-trailing**.

Duo-servo Brakes

Duo-servo drum brakes consist of the following components:

- Brake drum
- One primary shoe and one secondary shoe with friction linings
- Wheel cylinder
- Anchors
- Backing plate
- Adjusting screw
- Return springs, hold down springs, connecting springs
- Adjusting linkages and springs

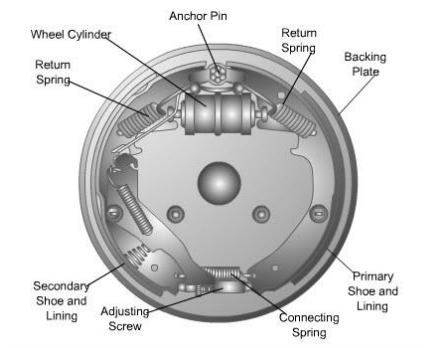

Brake Drum

The drum provides a friction surface to which the brake shoes are applied. When the shoes and drum come together, they convert the kinetic energy of the moving vehicle into heat, which then dissipates. The brake drum rotates with the wheel. In some brake systems, the drum contains the wheel hub and the wheel bearings. If the drum contains the hub, the drum provides the mounting hardware for the wheel and tire assembly. If the drum and hub are separate, the hub provides the mounting hardware for both the drum and the wheel/tire assembly.

The brake drum must be perfectly round and concentric with the spindle or axle. Brake pedal pulsation occurs if the drum is out of round or nonconcentric with the spindle or axle. Deep grooving in the drum friction surface prevents new shoes from conforming to the drum. Because the grooves in the drum surface key into the component that cuts them, grooved drums can be difficult to remove.

Brake Shoes

When the driver depresses the brake pedal, hydraulic pressure from the wheel cylinder forces the shoes against the rotating brake drum, thus producing friction that transforms kinetic energy into heat. **Brake shoes** are arc-shaped to conform to the brake drum surface. **Brake lining**, a layer of special friction materials, is either bonded (glued) or riveted to the brake shoes.

Wheel Cylinder

The wheel cylinder consists of the following parts:

- Cylinder
- Two pistons
- Two lip seal piston cups
- Expander spring assembly
- Two protective dust covers
- Two actuating pins (some models)
- Bleeder valve

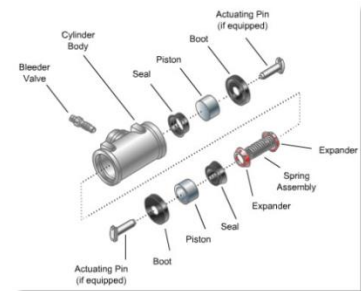

When the driver applies the brake pedal, hydraulic pressure from the master cylinder moves to the wheel cylinder. In the wheel cylinder, hydraulic pressure causes the cylinder cups to push the pistons outward. The action of the cylinders forces the brake shoes against the drum. When the driver releases the brake pedal, this relieves the hydraulic pressure. The brake shoe return springs then pull the shoes back against their anchor(s) and retract the wheel cylinder pistons. Wheel cylinders connect to the master cylinder through a series of steel tubes and special rubber high-pressure hoses. The wheel cylinders are always fastened firmly to the brake backing plate. Each wheel cylinder has a bleeder valve that allows the removal of air from the cylinder.

Backing Plate

The **backing plate** is a steel disc that firmly connects to the spindle or the axle housing. The backing plate cannot rotate. The backing plate provides a foundation for the drum brake system. The anchor(s) and wheel cylinders, including the brake shoe return springs and some of the adjuster linkages, are fastened to the backing plate. The plate has built-in pads on which the brake shoes can move.



Shoe hold-down devices are springs and pins that hold the brake shoes against the backing plate. This allows them to slide outward to the drum when the driver applies the brakes. The brake shoe return springs either return shoes to their rest position or pull the brake shoes away from the drum. In some systems, the return springs help control the automatic adjusters.

Brake Anchors

A **brake anchor** is a round piece of steel that either connects to the backing plate or threads into the spindle through a hole in the backing plate. Anchors bear all the force that the brake shoe(s) apply to the drum and therefore must be very solid. Most servo systems use one anchor per wheel. Some non-servo systems use two anchors per wheel, one for each shoe.

Duo-Servo Brake Operation

When duo-servo brakes are in the released position, return springs hold the bottoms of the shoes against the adjusting screw while the tops of the shoes are held against the anchor pin. As the brake pedal is pressed, the following occurs:

- Hydraulic pressure from the master cylinder to the wheel cylinder forces both wheel cylinder pistons outward to press the shoes against the drum.
- As the brake shoes contact the rotating drum, frictional force causes both shoes to rotate slightly. This action causes the secondary shoe (the one toward the rear of the vehicle) to jam against the anchor pin and forces the wheel cylinder piston back into the wheel cylinder.
- The rotating action of the primary brake shoe (the front one) causes the secondary shoe to wedge into the drum with a force that is greater than the just the hydraulic pressure would cause.
- Because of the wedging action, both shoes must be pulled away from the drum (by the return springs) when the brakes are released. Additionally, there are other springs that hold the brake shoes in place and return the adjuster arm after it actuates.
- As a result of this design, the secondary shoes must perform more of the braking than the primary shoes. Therefore, the secondary shoes usually wear more and are typically larger than the primary shoes.

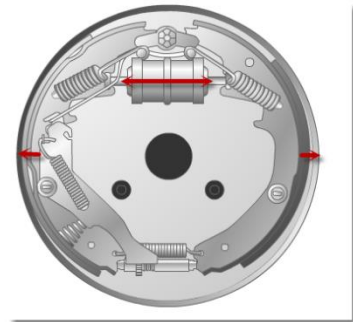

As a general rule-of-thumb, the heavier a drum-brake-equipped vehicle is, the more likely it is to have a duo-servo brake system.

Self-Adjusters

Drum brake systems have a self-adjust capability to compensate for wear on the brake shoes. A self-adjuster mechanism consists of a series of links, springs, retainers and a star wheel (screw) adjuster. The rotational action of the brake shoes activates the self-adjuster linkage when the brakes are applied and the vehicle is moving in reverse. As the clearance between the shoe and drum increases, the distance that the shoe moves also increases. When a predetermined amount of shoe movement occurs, the linkage moves the adjuster's star wheel, adjusting the clearance. The three types of automatic adjuster linkages are lever, cable, and link.

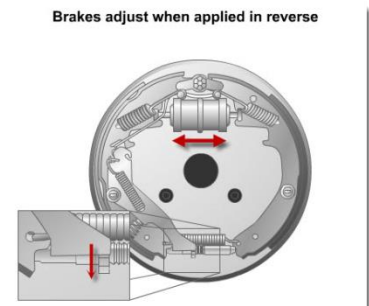

- Note:**
- In servo brakes, the adjuster is a threaded link that bridges the end of the brake shoe located opposite the anchor.
 - Servo brake adjusters can be used only on the side of the vehicle where they were originally installed. They are not interchangeable from one side to the other.

Leading-Trailing Brake Operation

There are three major differences between duo-servo and leading-trailing drum brakes:

- Leading-trailing systems have the anchor pin mounted at the bottom of the backing plate rather than at the top.
- Neither shoe pushes against the other in leading-trailing.
- Leading-trailing drum brakes are automatically adjusted when the parking brake is applied and released.

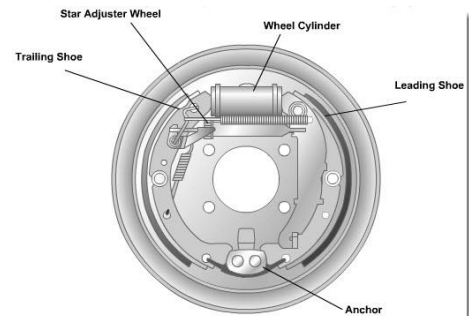

When the brake pedal is pressed a wheel cylinder pushes equally on each brake shoe. In turn, this forces the top of each shoe outward toward the drum, and each shoe pivots on the anchor located at the bottom of the backing plate. Drum friction pulls the leading (forward) shoe into tighter contact with the drum and aids the hydraulic force of the wheel cylinder. This action provides most of the braking force. The secondary shoe is not self-energizing as in Duo-servo but does provide some braking force due to the action of the wheel cylinder. When backing up, the opposite action takes place. In leading-trailing systems both the primary and secondary brake linings are typically identical in size. As a general rule-of-thumb, the lighter a drum-brake-equipped vehicle is, the more likely it is to have a leading-trailing brake system.

Chapter 2: Servicing Drum Brakes

Disassembling, Inspecting, and Servicing the Drum Brake System

Procedures for disassembling and inspecting a drum brake assembly

Use proper lifting equipment to raise the vehicle.

CAUTION: When lifting a vehicle, always use proper lifting equipment and observe all safety precautions.

Encapsulate and clean all brake drum assemblies to be serviced. Be sure to follow the latest federal procedures when encapsulating and cleaning brake assemblies.

CAUTION: Asbestos is a cancer-causing substance. Do not breathe asbestos dust or allow it to escape into the air.

With the encapsulator still connected to the brake assembly, remove the brake drum and once again clean the drum and brake assembly components.

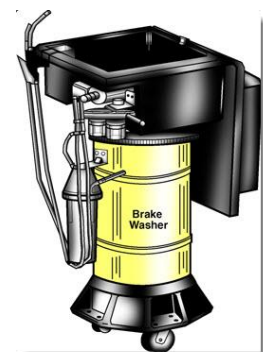

Note: In most cases, the brake adjusters must be loosened before the drum is removed.

- Inspect the general condition of the drum. Note if the drum is belled, barreled, or grooved. Also note if the drum is warped or distorted. Look for cracks or blue spots on the drum.
- Determine the drum's discard diameter. The discard diameter is often stamped on the drum. The vehicle's service information also provides the discard diameter.
- Using a drum micrometer, measure the drum's diameter. Always measure from the inside rims of the drum. Take measurements at several points on the drum.
- If all the micrometer measurements vary less than .010 in, the drum is concentric and should next be checked for grooving.
- If the drum is not concentric, it can be machined if its lowest micrometer reading is below .010 in. If the drum's lowest micrometer reading is above .010 in, discard the drum.
- Check the drum for grooves. Estimate the depth of any grooves. Determine if machining the grooves will cause the drum to exceed its discard diameter.



- Notes:**
- A groove increases the drum's diameter by twice the depth of the groove.
 - Minor grooving is acceptable if the drum does not exceed its discard diameter.
 - On some vehicles, the wheel hub is an integral part of the drum. When inspecting the wheel bearings on these vehicles, make sure that the bearing cups are in good condition and are firmly pressed into the hub.
 - If the wheel hub was not removed during drum removal, remove and service the wheel bearings, if possible.

- Notes:**
- Usually, the rear hub bearings in front-wheel-drive vehicles cannot be serviced. If the bearings are excessively worn or damaged, replace the hub assembly.
 - If installing new brake shoes, carefully compare the new ones with the old. Check the shoes' spring holes and arc diameter. Also check the shape of the shoes' ends and length of the shoes' friction material.
 - Only one drum brake assembly should be taken apart at a time. This prevents confusing parts from one assembly with those from another. The assembled brake components can also be used as a guide to reassembly.

Using the brake spring tool, remove the brake shoe return springs from the anchor.



Using the hold-down spring tool, remove the brake shoe hold-down device on both shoes.

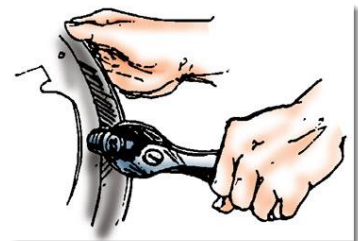

Disconnect the adjuster linkage from the anchor.

Grasp both shoes at their tops and pull them away from the anchor.

Note: When pulling the rear-wheel brake shoes away from their anchors, separate the parking brake lever from the secondary shoe. Sometimes it is necessary to disengage the lever from a notch. In other situations, it is necessary to remove a clip from a pin that retains the lever. In either case, leave the lever hanging on the cable while servicing the other components.

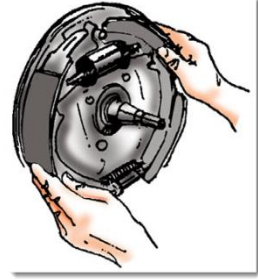

Service the wheel cylinder. If the shoes are replaced, the pistons run deeper into the cylinders. New shoes also cause the cylinder cups to run on a different part of the cylinder.

Note: Wheel cylinder service is discussed later in this lesson. Anytime the brake shoes are replaced, service the wheel cylinders.

Clean the backing plate with a noncontaminating solvent. Make sure to remove all dirt, rust, and loose scale from the plate.

Carefully inspect the shoe pad areas for grooves and other signs of wear. File the shoe pad areas flat or replace the backing plate as necessary.

Next, lightly lubricate the backing plate shoe pad areas with a lubricant designed to withstand high temperatures.

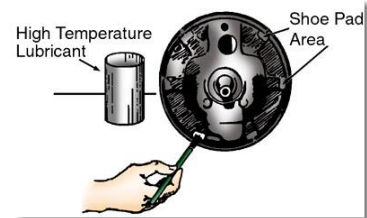

Clean and lubricate all brake hardware. Check the springs for corrosion and distortion. Replace any components of questionable quality.

Clean and lubricate the adjusters according to the manufacturer's procedures.

Inspecting and Diagnosing the Drum Brake System

Visually inspecting the drum brake system

Note: A visual inspection is the only reliable method of determining the condition of brake components. Remove the brake drum before making a visual inspection.

- Check the fluid level in the master cylinder and inspect the brake hydraulic system.
- Use proper lifting equipment to raise the vehicle. Remove the wheels.

CAUTION: When lifting a vehicle, always use proper lifting equipment and observe all safety precautions.

- Encapsulate and thoroughly clean the drum.

CAUTION: Asbestos is a cancer-causing substance. Never breathe asbestos dust or allow it to escape into the air. Special equipment is available to encapsulate the dust and prepare it for safe disposal. If this equipment is unavailable or in poor working order, do not perform brake work.

CAUTION: Carefully follow the manufacturer's instructions when using the encapsulator.

- After ensuring that the encapsulator is in place and the vacuum and compressed air are on, remove the brake drum. In some systems, the drum can be removed from the wheel hub. In other systems, it is necessary to disassemble the wheel bearing before removing the drum.

Notes:

- If the wheel bearing is disassembled, be sure to clean and repack it before reassembling the hub.
- It may be necessary to remove the encapsulator to make this adjustment. If so, be sure to reinstall the encapsulator and clean it out before removing the brake drum.

CAUTION: Do not remove the brake drum until the encapsulator is in place. Be sure that the encapsulator vacuum is on and running and that the compressed air is on.

If brake drums are grooved by the brake shoe rivets as a result of badly worn shoes, the grooves may mate with the rivets, making brake drum removal difficult. If this occurs, back off the brake adjuster.

To back off the adjuster plate, turn the star wheel with a brake spoon. An opening in the backing plate or the brake drum provides access to the adjuster. This opening may be closed with rubber plugs. In the brake drum, the opening may be a knockout in the drum. In either case, be sure to close the opening with specially designed rubber plugs.

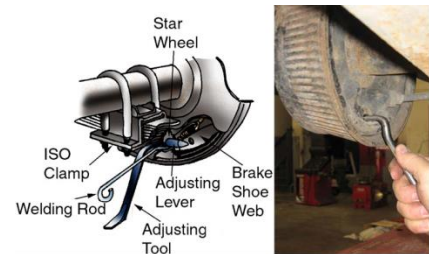

Note: It may be necessary to remove the encapsulator to make this adjustment. If so, be sure to reinstall the encapsulator and clean it out before removing the brake drum.

- When removing the brake drum, lay it down inside the encapsulator housing and blow off all the dust. Turn it over and finish blowing off the dust.
- Blow off all of the dust from the brake assembly. Make sure to blow off all of the dust - even the dust that is behind the parts.
- Using the gloves in the encapsulator, position the unconnected brake parts to thoroughly clean them with compressed air. To get all of the dust out, vacuum the enclosure thoroughly using compressed air.
- After completely freeing the encapsulator enclosure and all of the brake parts of brake dust, remove the encapsulator from the wheel.

Inspect the brake

1. Carefully inspect the brake assembly and note any indication of fluid leaks. Identify the source of any leaks.

Notes:

- If the rear brake on a rear-wheel-drive vehicle is contaminated with a heavy lubricant, replace the axle seals as well as the brake shoes.
- Do not use engine solvent on brake parts. Use only a solvent made specifically for brakes. Engine solvents and gasoline contaminate brake parts and may cause brake failure.

2. Inspect the brake lining.

Check the thickness of the brake lining:

- Some linings are riveted to the shoe.
- The rivet heads should be at least 1/64 in below the lining surface.
- The lining that is bonded to the shoe should be at least as thick as the shoe itself.
- Replace any shoes that do not clearly meet thickness standards.

Note: Periodically check the brake lining on all vehicles. Annual checks are recommended for vehicles with more than 40,000 miles. Also check friction material if there are unusual sounds during braking or if the brakes fade, pull, vibrate, or lose power.

Check the brake lining for cracks, loose rivets, missing or damaged areas, or any other problems.

3. Inspect the backing plate for cracks and distortions; replace the plate if cracks or distortions are found. Make sure the plate is securely mounted. Also check the backing plate shoe contact locations. If these locations are grooved, file the areas or replace the backing plate.

4. Inspect the brake shoe return springs for cracks and distortion. Make sure the springs are connected at both ends.

5. Make sure the hold-down springs are not distorted and the pins are not bent.

6. Brake inspection points:

- Make sure that the lever is not rounded at the point where it contacts the star wheel. Ensure that the wheel is not missing any teeth and that the adjuster threads are free to turn.
- Make sure that the adjuster lever is positioned properly for its adjustment.

Note: Remove, disassemble, and clean the self-adjuster if it is dirty or hard to rotate. In servo brakes, the adjuster can be removed and cleaned without disassembling the entire brake.

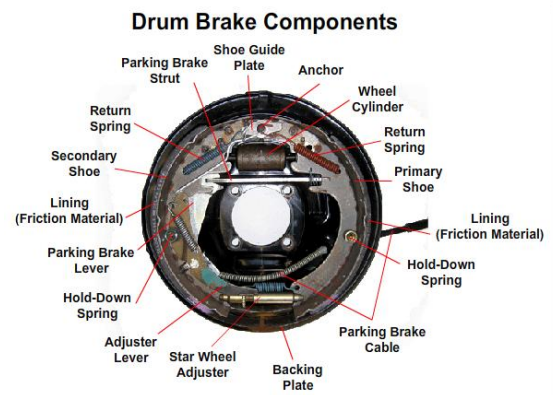

7. Inspect the anchor. Make sure the anchor is firmly connected. The return springs should hold both shoes firmly against the anchor. If either shoe is not held against its anchor, determine the reason why. If the parking brake is applying pressure to the rear-wheel brake shoes, remove the pressure by adjusting the parking brake cable adjustment.

Note: When the parking brake is released, the parking brake cable should never move either shoe off the anchor.

8. Look for wetness around the wheel cylinder dust boots. Look for any other signs of leaks.

9. Inspect the brake drum. Inspect the general condition of the drum. Note if the drum is belled, barreled, or grooved. Also note if the drum is warped or distorted. Look for cracks or blue spots on the drum. Determine the discard diameter of the drum. The discard diameter is often stamped on the drum.

The vehicle's service information also provides the discard diameter. Using a drum micrometer, measure the diameter of the drum. Always measure from the inside rims. If all the micrometer measurements vary less than .010 in, the drum is concentric and should next be checked for grooving.

- If the drum is not concentric, it can be machined if its lowest micrometer reading is below .010 in.
- If the lowest micrometer reading of the drum is above .010 in, discard the drum.

Check the drum for grooves. Estimate the depth of any grooves. Determine if machining the grooves will cause the drum to exceed its discard diameter.

- Notes:**
- A groove increases the diameter of the drum by twice the depth of the groove.
 - Minor grooving is acceptable if the drum does not exceed its discard diameter.
 - On some vehicles, the wheel hub is an integrated part of the drum. When inspecting the wheel bearings on these vehicles, make sure that the bearing cups are in good condition and that they press firmly into the hub.

During brake inspection, the adjuster can be removed and cleaned without taking apart the entire brake assembly. Below is a general procedure for disassembling, cleaning, and reassembling the adjuster.

Note: Take apart only one drum brake assembly at a time. Doing so prevents confusing parts from one assembly with those from another. Use the assembled brake components as a guide for reassembly.

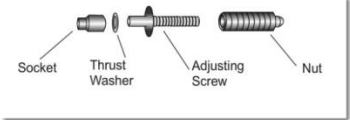
- Using a large screwdriver or similar tool, pry apart the adjuster end of the shoes enough to allow removal of the adjuster.
 - Unscrew the link and clean the threads with a wire brush.
 - Remove the socket. Do not lose the thrust washer located between the socket and adjusting screw.
 - Lightly lubricate the threads of the adjuster screw and socket with an approved lubricant. Make sure that the thrust washer is in place.
 - Reassemble the adjuster. Screw the adjuster link to its shortest adjustment.
- 
- Spread the brake shoes sufficiently to replace the link. Make sure that the adjuster lever is properly positioned to turn the star wheel.
 - Using a brake shoe gauge, adjust the link to fit the drum.
 - After inspecting the brake and making all necessary repairs, replace the drum and wheel.

Disassembling and Inspecting the Wheel Cylinder

Procedure for wheel cylinder service

Note: A wheel cylinder is not normally disassembled for inspection unless there are specific reasons for doing so. Usually, if the cylinder is not leaking and the exposed rubber parts are not deteriorated, the wheel cylinder is considered serviceable. However, if there is evidence of leakage or deterioration of the exposed rubber parts, then remove the wheel cylinder and either replace or recondition it. The following steps determine if replacement is necessary.

Note: Before removing the wheel cylinder, remove the brake shoes and other components.

- Disconnect the brake line or hose from the wheel cylinder. In some cases, the brake hose remains connected to the cylinder and disconnects at the hose's other end. Check the proper service information for the correct procedure.
- Remove the wheel cylinder from the backing plate. Bolts connect some wheel cylinders to the backing plate; a snap ring holds other wheel cylinders in place.
- Remove and clean out the bleeder valve. The bleeder valve screws into the wheel cylinder.
- Remove the rubber dust caps from the ends of the wheel cylinder.
- Push out all the wheel cylinder's inner components - pistons, springs, cups, etc. In some stepped cylinders, it is necessary to push the inner components from the small end to the large end.
- Discard the rubber dust caps, rubber cups, and spring.
- Carefully clean the wheel cylinder and two pistons with a solvent approved for brake systems.
- Examine the cylinder bores and both pistons. Look for varnish, pitting, and scoring.

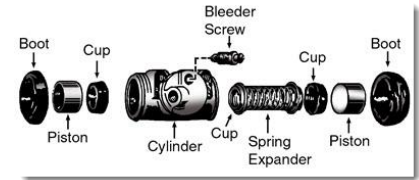

Note: Remove varnish on the cylinders and pistons with alcohol or other approved solvents. Sometimes it is possible to hone out pits and scoring in cylinders. Some manufacturers, however, discourage honing cylinders; check the proper service information for recommendations. Replace pistons that are scored or pitted.

- Lightly hone the wheel cylinder, if necessary. Be sure to verify if the manufacturer indicates if the wheel can be honed; also be sure to follow the manufacturer's recommended honing procedures.
- After honing the wheel cylinder, wash the cylinder with a brake cleaning solvent.
 - Make sure that all parts are well lubricated with a clean brake fluid or another approved brake assembly lubricant.
 - Install new cups and a new spring. Push both cups into the cylinder, thereby compressing the spring. The cups should face inward toward the spring.
 - Install both pistons with the flat sides facing toward the cups. Then push the pistons into the cylinder until they are flush with the cylinder.
 - Install the dust caps. The dust caps should retain the pistons.
- Install the bleeder valve. Make sure that the bleeder valve is clean and clear.
- Install the wheel cylinder. Bolts retain some wheel cylinders; spring clips retain other wheel cylinders.

Some non-servo brakes use two one-piston cylinders that are adjustable in some cases. Make sure that these cylinders adjust easily.

- Install the brake line or hose according to the repair manual procedures.
- Install the pins that move the brake shoes.

Installing and Adjusting Drum Brake Components

CAUTION: Always performance test the brake system after all repairs.

Install the brake shoes

Examine the new brake shoes and determine if there is a difference between the shoes. Most dual servo brakes use two different shoes on each wheel. If this is the case, the brake lining on one shoe is longer than the other. Use the shoe with the longest lining in the secondary position.

Assemble the two shoes located on one side by connecting the adjuster end of the shoe with the spring and the adjuster. The star wheel and the secondary shoe are located toward the rear of the vehicle.

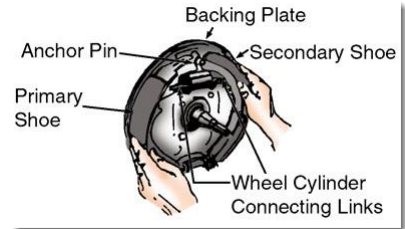

Spread the shoes and slip them over the anchor, ensuring that they both properly engage the wheel cylinder pins.

Note: In some cases, it is necessary to connect the adjuster linkage at this time.

Note: On rear-wheel brakes, install the parking brake lever at this time.

Install the hold-down springs.

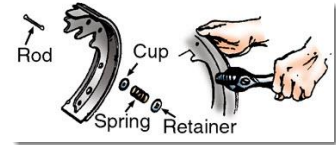

Using the brake spring tool, install the brake shoe return springs. Examine the shoes and make sure that they both contact the anchors and that the adjuster operates properly.

Adjust the Brake Shoes

- Adjust the brake shoe gauge to fit the drum. Tighten the knob to lock the gauge into the proper position.
- Adjust the star wheel outward until the center of the brake shoes touches the gauge.

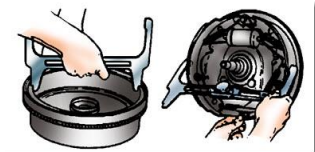
Examine the parking brake linkages

- Make sure to disengage the parking brake.
- Make sure the cables are free in their housings.
- Make sure the brake shoes rest against their anchors. If the parking brake prevents a brake shoe from contacting the anchor, adjust the length of the parking brake cable. (The cable adjustment mechanism is usually found at some point on the cable.) Recheck the shoes.

Install the drum

If the hub is part of the drum, be sure that the wheel bearing has been serviced.

Install and torque the wheel.

If installing the drum brakes on the rear wheels, adjust the parking brake at this time. Follow the manufacturer's recommendations and procedures.

Brake Drum Inspection

Any time brake service is performed, all brake drums should be inspected for the following:

- Excessive wear or scoring
- Hot spots or heat checks
- Out-of-round
- Distortion
- Cracks

Any brake drum that is cracked must be replaced. Those that have hot spots, distortion, or are out-of-round can cause braking problems such as pulling, vibration, chatter, noise and pulsation. Many times these drums can be refinished and reused; other times they must be replaced. Drums that exhibit minor scoring but have no other problems can sometimes be reused without refinishing; however, it is critical that the diameter of a drum be measured to determine if it can be safely refinished and reused.

Installing the Wheel and Tire Assembly

To install the wheel and tire assembly:

- Inspect the condition of wheel studs and lug nuts.
- Replace any studs or nuts that are defective.
- Check and inflate the tires to recommended pressure.
- Clean dirt and corrosion from the wheel hub mounting area and from the center pilot hole of the wheel.
- Place the wheel on the hub and install the lug nuts finger-tight.
- Using the proper wrench, tighten the nuts alternately to draw the wheel evenly against the hub.
- Manually lower the vehicle and finish tightening the lug nuts with a torque wrench to the manufacturer's specified torque rating.
- If the wheels are equipped with a tire pressure monitoring system, perform the procedure to register the wheels with the system in their new location.



Machine Brake Drums

Note: Before performing the procedure below, perform the following steps: properly lift and support the vehicle, encapsulate and thoroughly clean the asbestos dust from each brake assembly, and remove the drum of each brake assembly.

CAUTION: Asbestos is a cancer-causing substance. Do not breathe asbestos dust or allow it to escape into the air.



Mount the drum on the machine's arbor. Be sure to use the proper attachment hardware. Follow the manufacturer's instructions.

CAUTION: Make sure that all controls are in neutral or at zero before turning on the lathe.

Note: Firmly center the drum perpendicularly to the arbor. If the drum appears to be mounted improperly, review the mounting instructions. Start the lathe. If the drum wobbles or tramps excessively, reposition it on the arbor.

Install the silencer band (usually a rubber strap wrapped around the drum). The silencer band prevents the drum from vibrating. Failure to use this band results in an inferior drum finish.

Install the tool bar. Make sure that the cutting tool faces the drum friction surface.

Position the tool bar. Move the cutting tool away from or toward the drum with the spindle feed handwheel.

Turn the cross-slide's handwheel so that the cutting tool is positioned over the unused portion of the brake surface at the outer edge of the drum.

Turn the cross-slide's handwheel until the cutting tool barely touches the brake drum surface. Then note the depth of cut reading. Turn the cross-slide's handwheel counterclockwise one-half turn.

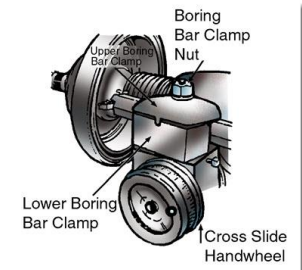

CAUTION: Make sure that all controls are in neutral or at zero before turning on the lathe.

Turn on the lathe.

With the drum in motion, turn the cross-slide's handwheel until the cutting tool barely touches the drum. Allow the tool to scratch the drum.

Examine the scratch. If the scratch goes all the way around the drum, then the drum is square and can be reworked as is.

If the scratch goes only part of the way around the drum, then loosen the drum and turn it 180° on the arbor and scratch it again approximately 1/8 in from the original scratch.

- If the scratches are now parallel, then the drum can be reworked as long as doing so does not increase the drum diameter beyond the discard specification.
- If the scratches are not parallel, then the drum is not centered on the arbor or the arbor is bent. Do not rework the drum until any problems are corrected.

Using the following procedure, rework the drum.

- Make sure that all controls are in neutral or at zero before turning on the lathe.
- Using the handwheel that positions the arbor, set the cutting tool at the drum's farthest inside point.
- Using the handwheel that sets the depth of cut, move the cutting tool until it almost touches the drum's friction surface.

Turn on the lathe.

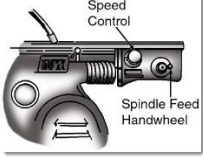
- With the drum in motion, turn the handwheel that sets the depth of cut until the cutting tool touches the drum's friction surface. After the cutting tool contacts the drum, index the collar on the handwheel to zero.
 - Set the depth of cut at no more than .010 in for rough cuts and no less than .004 in for finish cuts.
 - Set the arbor speed control knob at the speed desired for the cut.
 - Set the arbor travel-limiting collars.
 - Lock the cross-slide by tightening its locking knob.
 - Engage the arbor travel bar.
- 
- Continue taking cuts until the friction surface is smooth and true.
 - Make the last (finish) cut at the slowest speed.
 - Make sure that the drum does not exceed its discard diameter after machining.
 - Also make sure that the drums used on the same axle are as close in diameter as possible.

Brake Service Tips

Always inspect and measure the brake drums when replacing brake linings or if any of the following symptoms occur:

- Pulsation
- Brake fade
- Chatter
- Wheel drag
- Brakes too sensitive
- Spongy pedal

Resurface drums if:

- Taper or out-of-roundness exceeds 0.006 inch (0.15 mm)
- Scoring exceeds 0.060 inch (1.52 mm)

Replace drums if:

- The maximum diameter reading equals or exceeds the discard dimension.
- The drum is under the discard dimension but refinishing would not leave at least 0.030 inch (0.76 mm) allowance for wear.

Unit 4: Disk Brakes

Chapter 1: Introduction and Servicing Calipers

Disc Brakes

Disc brakes are used on the front of all modern vehicles, while some have both front and rear disc brakes. The advantages of disc brakes over drum brakes include:

- Better fade resistance
- Reduced pulling and grabbing
- Self-adjustment capability

Disc brakes consist of the following components:

- Rotor
- Hub
- Caliper assembly
- Brake pads
- Mounting bolts

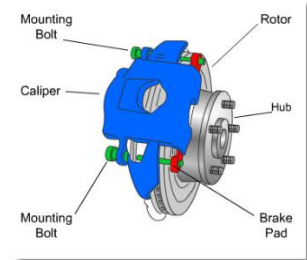

Brake systems must dissipate tremendous amounts of heat or the brakes will fail. Because of their exposure to the surrounding air, disc brakes dissipate heat more quickly than drum brakes. Some rotors are ventilated, allowing air to circulate between the friction surfaces and dissipate heat even more efficiently. Because disc brakes can clean and cool themselves, they are generally considered to be more effective than drum brakes.

Disc Brake Caliper

The disc brake caliper converts hydraulic pressure from the master cylinder to a mechanical force that pushes the brake pads against the rotor. The caliper body is a U-shaped casting mounted over the rotor and is typically made of iron or aluminum.

All calipers, regardless of design, contain these major parts:

- Caliper body or housing
- Internal hydraulic passages
- One or more pistons
- Piston seals
- Dust boots
- Bleeder screw
- Inboard and outboard brake disc pads
- Mounting bolts

The most common types of disc brakes are the floating caliper and the sliding caliper. Both the floating and sliding calipers operate identically and the only difference is in the mounting. Specifically, floating calipers slide on mounting bolts and bushings while sliding calipers operate on machined guides and bushings.

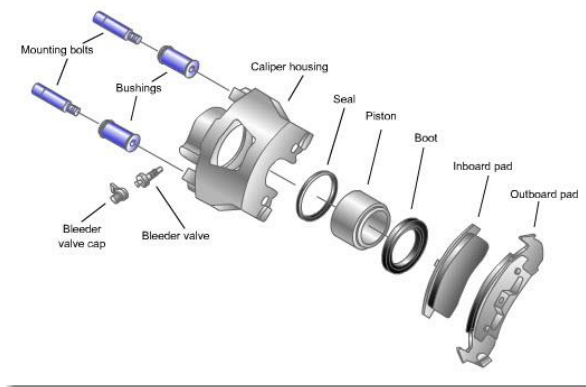

Floating Caliper

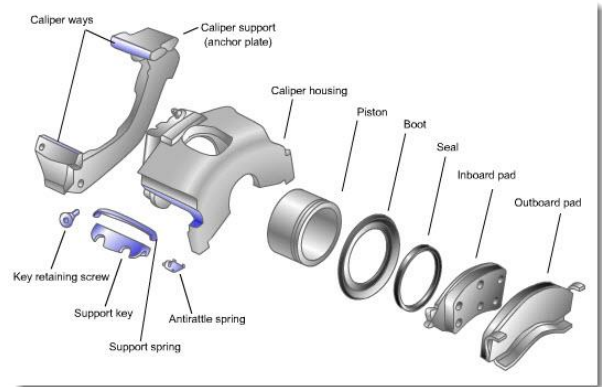

Sliding Caliper

Disc brakes may also use a fixed caliper design.

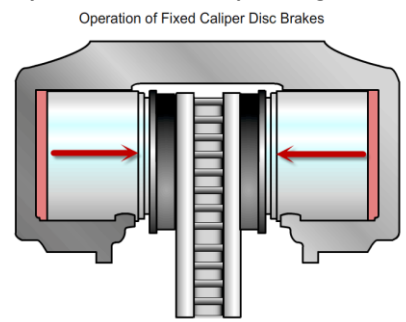
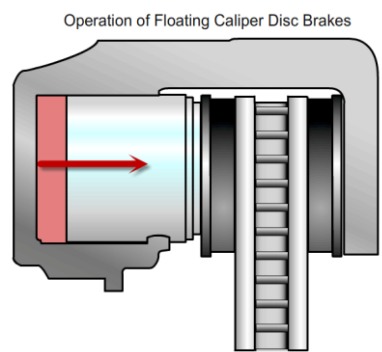

Note: While drum brakes use brake return springs, calipers do not. Instead, seal deflection releases the brake pads.

Disc Brake Seal and Piston Action

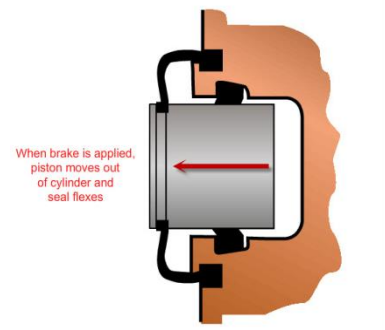

Inspect and Diagnose Disc Brake Systems

Visually inspecting the disc brake system

- Check the fluid level in the master cylinder and inspect the brake hydraulic system.
- Use proper lifting equipment to raise the vehicle. Remove the wheels.

CAUTION: When lifting a vehicle, always use proper lifting equipment and observe all safety precautions.

Note: If both brake pads are not visible after removing the wheel, remove the caliper.

- Encapsulate and thoroughly clean the disc and rotor.

- CAUTION:**
- Asbestos is a cancer-causing substance. Never breathe asbestos dust or allow it to escape into the air. Special equipment is available to encapsulate the dust and prepare it for safe disposal. If this equipment is unavailable or in poor working order, do not perform brake work.
 - Carefully follow the manufacturer's instructions when using the encapsulator.

Inspect the brake.

Carefully inspect the brake assembly and note any indication of leaks. Identify the source of any leaks.

Inspect the brake lining.

- Check the thickness of the brake lining on the pads.
- If the brake lining is riveted to the pad, the rivet heads should be at least 1/16 in below the lining surface to prevent contact with the rotor surface.
- Brake lining that is bonded to the pad should be at least as thick as the pad itself.
- Replace any pads that do not clearly meet the thickness standards. Note that brake pads can wear unevenly, so some may have to be replaced earlier than others.

- Notes:**
- Periodically check the brake lining on all vehicles. Annual checks are recommended for vehicles with more than 40,000 miles. Also check the brake lining if there are unusual sounds during braking or if the brakes fade, pull, vibrate, or lose power.
 - If there is any doubt about the condition of the friction material, remove the caliper to allow for more careful inspection.
- Replace the pads if the brake lining is cracked, worn, glazed, distorted, or saturated with fluid. Also replace the pads if the backing plates are distorted or saturated with fluid.

Brake pad wear indicator systems

There are two common types of disc brake pad wear indicators. The first is the mechanical or audible wear indicator, which uses a strip of metal attached to the brake pad and positioned to make contact with the brake rotor when pad wear reaches a predetermined level. The metal strip rubs against the rotor producing a grinding or squealing sound to alert the driver.

The second type is the electrical/electronic brake pad wear indicator system that uses pads with electrical connectors embedded in the brake pad material. When the pads wear to a predetermined point, the electrical connectors in the pad come into contact with the rotor surface, which will open (or ground, depending on design) the circuit between the pad connectors and turn on a brake warning light on the instrument panel. To turn the brake warning light off, it is normally necessary to replace the brake pads, and on some vehicles, perform a warning light reset procedure.

Removing Disc Brake Calipers

Always use proper lifting equipment to raise the vehicle.

CAUTION: When lifting a vehicle, always use proper lifting equipment and observe all safety precautions.

Remove the wheels.

- Mark the wheels for reinstallation in their original locations.
- Inspect the wheels for cracks and check the tires for unusual wear patterns. Store the wheels so that the wheel covers do not become damaged.
- Identify whether the calipers to be serviced are fixed or floating. A floating caliper contains only one piston. Fixed calipers usually contain four pistons - two on each side.
- Encapsulate and clean all brakes to be serviced.

CAUTION: Asbestos is a cancer-causing substance. Do not breathe asbestos dust or allow it to escape into the air.

- Take off the master cylinder cover and remove a small amount of fluid from each chamber. Doing so prevents fluid overflow when the caliper pistons are compressed.

CAUTION: Brake fluid can harm a vehicle's finish. Do not let the fluid overflow or spill.

- Compress the caliper pistons. Outlined below are procedures for compressing pistons on both fixed and floating calipers.

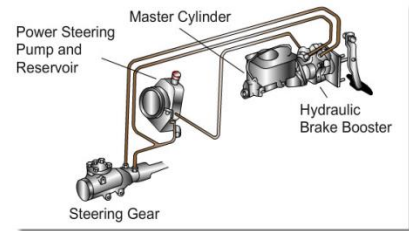

Procedures for compressing pistons on fixed calipers

- Compress the fixed caliper pistons one at a time. Insert a small pry bar or similar tool between the brake pads and pry them apart. Doing so forces the pistons into the caliper bores.
- If one piston is stuck in its bore, compress the other three and force the caliper off the rotor.
- If more than one piston is stuck and the stuck pistons are located across from each other, attempt to force the caliper off the rotor.

Note: Although it may be difficult to force off a caliper in which three pistons are stuck, make the best effort possible. Forcing the caliper off the rotor is usually the easiest and quickest removal procedure.

- If the rotor is deeply grooved or if the caliper cannot be forced off the rotor, remove the caliper and rotor together.

Note: Replace the caliper and rotor if they must be removed together.

Procedures for compressing pistons on floating calipers

- Place a large C-clamp on the caliper. Place the clamp screw against the outer brake pad.
- Turn the screw so that the outer pad forces against the rotor. As a result, the caliper slides and forces itself against the inside of the rotor. This pad and caliper movement forces the piston into the caliper.
- Remove the caliper from the adapter.
- Be sure to disconnect the correct caliper fasteners.

Note: A common mistake is to remove the adapter from the knuckle.

- Inspect all attachment hardware and note any broken or worn parts. Be sure to mark parts for replacement.

- Hang the caliper by using a piece of wire or welding rod. Never allow a caliper to hang by the brake line.
- Disconnect the hydraulic system from the caliper.
- If the brake hose is connected with a banjo bolt, disconnect the hose at the caliper.
- If a disconnecting device is located at the end of the brake hose opposite the caliper, leave the hose on the caliper.
- If the cover has been off the master cylinder thus far during the procedure, put it back on.

- Notes:**
- On some rear-wheel disc brakes, the steel brake lines connect to the caliper. These calipers use a flexible hose above the rear axle to accommodate suspension movement. If the vehicle has independent rear suspension, then a flexible hose is provided to each rear-wheel caliper.
 - If the lines are left open for a long time, tape them to avoid contamination from dirt and moisture.

Inspecting and Repairing Calipers

Clean all brake components.

Note: Use only a brake cleaning solvent to clean the brake components. Never use an engine solvent or gasoline.

- Disassemble the caliper and remove its pistons.
- When servicing a floating caliper, use compressed air to blow out the piston. When servicing a fixed caliper, insert a rag pad between the pistons for protection and apply compressed air to the hydraulic port.
- In most cases, only the piston that is the most free moves.
- After one of the pistons leaves its bore, no more air can be trapped.
- Remove the other pistons one at a time with special pullers.

- CAUTION:**
- The piston can blow out of the caliper with enough force to cause personal injury. Make sure the rag pad is between the piston and the other side of the caliper. Cover the caliper with another pad to prevent parts from flying. Do not place fingers between the pistons and the caliper.
 - Do not use heat or machine tools to remove the pistons; doing so may ruin the caliper.

Note: It may take considerable time to remove stuck caliper pistons. If the pistons are stuck so securely that normal removal procedures cannot free them, then the bores are probably corroded and the entire caliper needs to be replaced.

Inspect the caliper components.

After cleaning all the internal parts with an approved brake solvent, inspect the pistons for pitting, rusting, cracks, chipping, and scoring. If any of these problems are found, replace the pistons.

Note: Whether damaged or not, always replace plastic pistons after removal.

Remove all seals and boots from the caliper bores. Check the bores for pitting and scoring. Clean the bores with a fine crocus cloth or caliper hone if doing so does not increase bore diameter by more than .002 in. If there is any bore damage deeper than .001 in, replace the caliper.

Note: Discard all seals, boots, and any other rubber caliper parts.

- Remove and clean the bleeder valve; replace it if necessary.
- Reassemble the caliper.
- During reassembly, lubricate all parts liberally with clean brake fluid or another appropriate lubricant. All parts should freely move into their proper positions; inspect any part that does not fit easily into its position. Do not force the pistons into their bores.
- Using only new soft parts, manually insert all seals and pistons into the caliper bores. Do not use excessive pressure. Press pistons to the bottom of their respective bores.

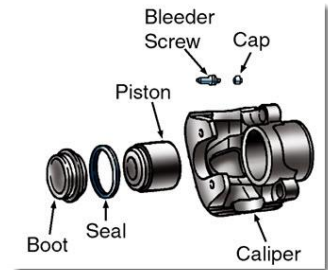

Install a new dust seal according to the manufacturer's directions.

- If the transfer passage is drilled into the body of a fixed caliper, clean the passage and make sure it is free of obstructions. If the transfer passage is a separate tube, clean the tube and ensure that it is free of obstructions before installation.
- **Note:** Floating calipers do not have transfer passages.
- On fixed caliper brakes, reassemble the caliper halves by using new gaskets or seals where indicated.
- Inspect all hoses and replace any that show evidence of leaking or deterioration.
- Reinstall all bleeder valves.

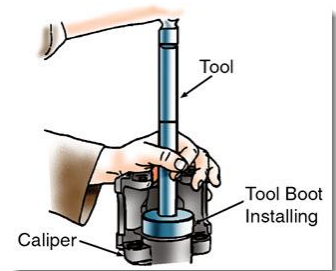

Installing and Adjusting Disc Brake Calipers

Inspect the caliper attachment hardware. If servicing a floating caliper, inspect the surface upon which the caliper floats. Repair any worn areas and thoroughly clean the adapter and knuckle.

- Clean and lightly lubricate all attachment hardware.
- Inspect the rotors for proper parallelism, runout, and minimum thickness. Make sure the rotors are not grooved in excess of allowable limits. Repair or replace rotors as necessary.

Note: Service or replace the rotors before installing the calipers.

- Using the manufacturer's directions, install the brake pads securely in the caliper. Fit the pads, if necessary.
- Using the manufacturer's directions, install the caliper.
- Install the brake hoses.

- Notes:**
- When servicing the fixed caliper brake systems, make sure that the caliper is adjusted to the rotor. Adjustments are usually made with shims. Be sure to follow the manufacturer's procedures.
 - Floating calipers used on front wheels require no adjustment.

CAUTION: Until the pistons return to their operating positions, the brakes are inoperative. The driver has to apply the brakes several times before the pistons resume their operating positions. Make sure brakes are operative before driving the vehicle.

- Bleed all air from the lines and the calipers; check the level of brake fluid in the master cylinder.
- If installing a rear-wheel caliper, connect the parking brake cable and adjust the parking brake according to the manufacturer's directions.

Note: There are two basic designs of parking brake mechanism used on rear disc brake vehicles. One type uses an expanding shoe and drum (a small mechanical drum brake system inside the disc rotor). The second type uses a screw-actuated unit that is an integral part of the caliper. Procedures for service and adjustment of these systems differ between one make and model and another. Use the manufacturer's recommended procedure.

- Reinstall the wheel/tire assembly and torque the wheel nuts to specifications.

CAUTION: Always check and refill the master cylinder after testing or servicing the hydraulic system components.

CAUTION: Always make sure the hydraulic system is free from air after testing or servicing the hydraulic components.

Chapter 2: Rotors

Determining the Cause of Pulsating Pedal or Brake Fade

A rotor that is too thin may cause a pulsating pedal or brake fade. Outlined below is a procedure for determining rotor thickness.

- Use proper lifting equipment to raise the vehicle. Remove the wheel.

CAUTION: When lifting a vehicle, always use proper lifting equipment and observe all safety precautions.

- Using a micrometer, measure the rotor thickness at 12 different points.
- Compare this measurement with the minimum thickness specification imprinted on the rotor or its hub. If the thickness is less than the specification, discard the rotor.

Check the rotor for grooves at this time.

- If significant grooves are not found, check the rotor for parallelism according to the procedure described later in this lesson.

- If significant grooves are found, measure the depth of the grooves.
- If grooving causes the rotor to fall below its minimum thickness at any point, discard the rotor.
- If the rotor is still above its minimum thickness, machine the grooves out of the rotor. Do not machine the rotor below its minimum thickness, however.

Note: Rotors can be reworked if they exceed their minimum thickness. To determine the rotor's thickness after reworking, measure to the bottom of the deepest grooves on both sides. If reworking causes the rotor to drop below its minimum thickness specification, discard the rotor.

Note: The manufacturer machines grooves into some discs. Do not measure these grooves when using the above procedure.

Procedure for determining if the rotors are parallel

Rotors that are not parallel may cause pulsating pedal or brake fade. Outlined below is a procedure for determining if the rotors are parallel. Using a micrometer, measure the thickness of the rotor at 12 different locations. Record each measurement. If any one reading exceeds any of the others by .001 in, the rotor is not parallel.

If the rotor is parallel, measure the rotor runout according to the procedure described later in this lesson. If the rotor is not parallel, calculate the rotor's thickness if it is machined to the smallest micrometer measurement. Discard the rotor if machining drops it below its minimum thickness.

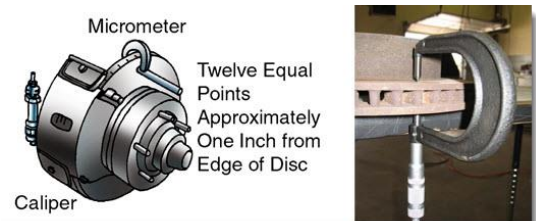

If machining does not drop the rotor below its minimum thickness, machine the rotor until there is no more than .001 in variation between any two points.

Note: Some minor grooving in the rotor after reworking is acceptable.

Measuring Rotor Thickness Variation

Rotors must be measured for thickness variation if the customer is experiencing a problem with a vibrating or pulsating brake pedal. Thickness variations can be caused by excessive heating and cooling of the rotor, and even a small variation can cause an adverse braking condition.

Precision brake micrometers must be used when measuring the thickness variation of brake rotors.

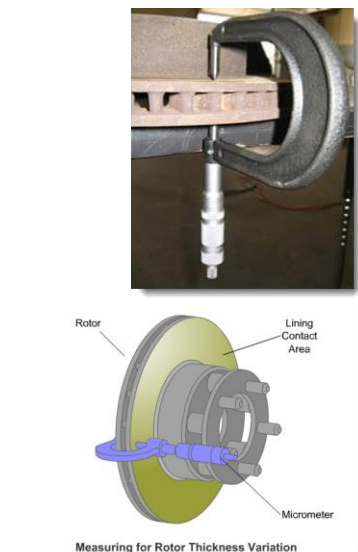

A difference of more than 0.0006 inch (0.0152 mm) between four measurements may require that the rotor be refinished or replaced during brake service (refer to vehicle service manual for specifications - some rotors may need refinishing with as little as 0.0003 inch variation).

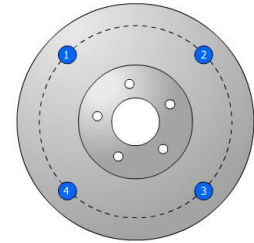

Measure rotor in four or more locations.

Rotor Refinishing

Rotors should be refinished only in cases of:

- Excessive lateral runout
- Excessive thickness variation
- Excessive surface scoring

Additionally, there are two specifications that must be observed when refinishing rotors:

Discard specification - is usually stamped or cast into the rotor. Rotors can be reused to this 'minimum thickness' specification if the rotor is not refinished.

Minimum refinish specification - This specification is found in the vehicle service manual and is the minimum refinish thickness. The difference between the discard and refinish specifications is to allow for the wear that takes place as the new pads burnish, or wear into, the refinished rotor.

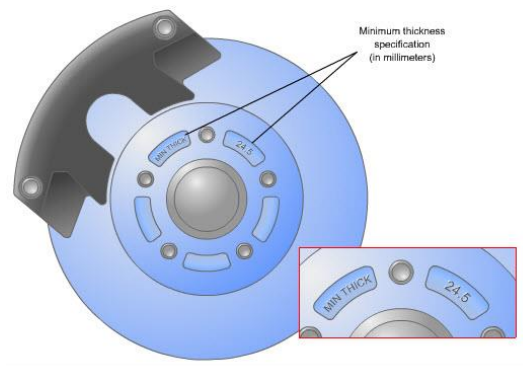

Machining Rotors off the Vehicle

Preparation for machining rotors

Mount the rotor on the brake lathe arbor.

Note: Be sure to center the rotor between the arbor's two cones. If the rotor wobbles when turned, make sure the rotor is correctly connected to the arbor. Also make sure that no dirt or chips are between the rotor and the arbor.

Install the rotor silencer. In most cases, the silencer is a rubber band that stretches around the rotor's edge. However, the silencer may be a pad that contacts the rotor's face.

Install the cutting tools. Make sure to center the rotor between the cutting tools. Also make sure that the cutting tools are perpendicular to the arbor.

Using hand pressure, rotate the rotor at least one complete turn. Make sure that the rotor turns freely and both tool bits are clear of the rotor's face.

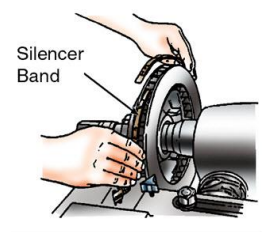

CAUTION: Make sure that all controls are in neutral or at zero before turning on the lathe.

Turn on the lathe.

- Turn one of the tool bit control knobs clockwise until the tool bit makes contact with the rotor's face.
- Turn the indexing collar on the knob to zero.
- Repeat this procedure on the other tool bit control knob.
- After setting the collars, do not change their position. Keep the collars in the same position during the entire machining process. The collars indicate how much material is being removed.

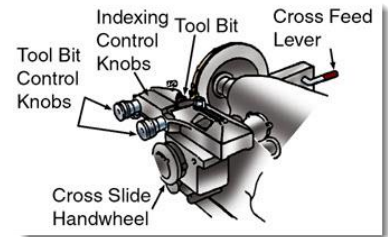

Using either of the tool bits, make a scratch cut on the rotor. If the scratch cut is all of the way around, rework the rotor without further adjustments. A scratch cut going only part of the way around the rotor may indicate that the rotor is not square on the arbor.

- Loosen the rotor and rotate the arbor 180°.
- Move the tool slightly and scratch the rotor again. If the two scratches run side by side, then the wobble is in the rotor and thus can be reworked.
- If the scratches are located across the rotor from each other, then the wobble is in the machine or in the space between the rotor and the arbor. Correct any problems with the machine or recheck the rotor mounting.

Machining the Rotor

Machine the rotor after making sure it is correctly installed on the arbor.

- Turn the cross-slide handwheel clockwise until the tool bits are on the most inward edge of the rotor's face.
- Turn the depth of cut knobs (tool bit control knobs) until they indicate the depth of the first cut. Then lock them in this position with the locking knobs.
- **Note:** If the first cut is made at high speed, the depth should not exceed .010 in. If the rework is less than .010 in, then set the depth at the rework dimension and run the first cut at low speed.
- Engage the cross-feed lever. The lever has two positions: high and low. High speed is for a rough cut and low speed is for a finish cut.
- **Note:** The depth of cut should never be less than .004 in. Cuts less than .004 in do not allow heat to transfer from the tool bit to the rotor. Excessive heat buildup in the tool bit may cause damage.
- Continue taking cuts until the rotor is smooth and true. Check the rotor's thickness, parallelism, and runout after making the final cut but before removing the rotor from the arbor.
- Using a sanding block or other abrasive, put a nonsymmetrical finish on the rotor's friction surface.
 - Turn on the brake lathe.
 - Lightly drag the abrasive across the machined surface of the rotor.
 - Turn off the brake lathe.
- Remove the rotor from the arbor.

Machining Rotors on the Vehicle

Preparation for machining rotors

- Use proper lifting equipment to raise the vehicle.

CAUTION: When lifting a vehicle, always use proper lifting equipment and observe all safety precautions.

Remove the wheel from the rotor to be serviced and encapsulate and clean the brake parts. Be sure to follow the latest federal procedures when encapsulating and cleaning brake assemblies and follow the manufacturer's instructions when using the encapsulator.

CAUTION: Asbestos is a cancer-causing substance. Do not breathe asbestos dust or allow it to escape into the air.

- Remove the disc brake caliper. Use service information to locate the correct procedure for the make and model of vehicle being serviced.
- Visually inspect and measure the rotor to determine if it can be resurfaced or must be replaced.

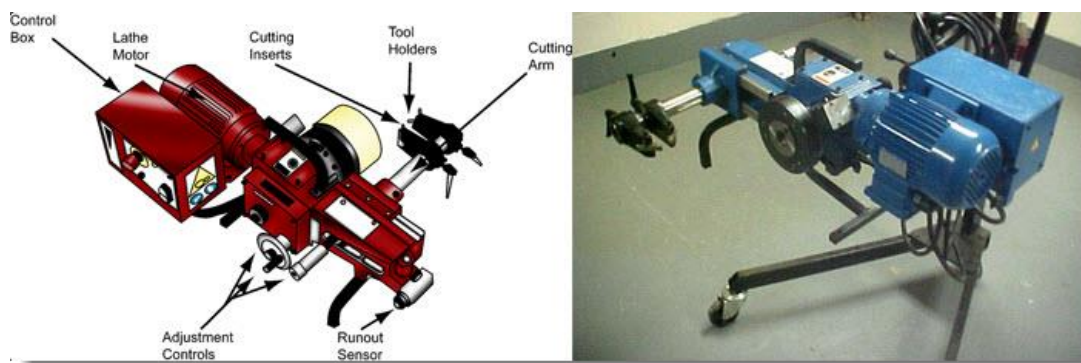

- Connecting the brake lathe
- Select the proper hub flange adapter to fit the vehicle's rotor/hub assembly.
- Mount the hub flange adapter to the rotor/hub assembly. Verify that all mounting areas are clean.
- Attach the brake lathe to the mounting flange adapter.

CAUTION: Be sure the lathe is properly aligned and mounted to avoid damaging the flange.

- Attach a dial indicator and compensate for hub and adapter runout.

Note: Some brake lathes have the ability to self-compensate.



Machining the Rotor

- Install the rotor silencer.
- Check the condition of the cutting inserts.
- Position the cutting inserts at the inner diameter of the rotor's inboard and outboard friction surfaces.
- Adjust the cutting inserts for the desired depth of cut.

Note: The depth of cut should never be less than .004 in. Cuts less than .004 in do not allow heat to transfer from the tool bit to the rotor. Excessive heat buildup in the tool bit may cause damage.

- Turn on the brake lathe.
- Engage the feed mechanism.

CAUTION: To avoid damaging the rotor, do not disturb the lathe once the feed mechanism has been engaged.

- Machine the rotor's surface.
- Remove the brake lathe from the adapter. Be careful not to hit the rotor with the cutting inserts while removing the lathe.
- Check the rotor's thickness, parallelism, and runout before removing the adapter. Be sure that the rotor is above the manufacturer's minimum thickness specification.
- Remove the hub flange adapter.
- Reinstall the brake caliper and pads. Use service information to locate the correct procedure for the make and model of vehicle being serviced.
- Depress the brake pedal and check brake operation.
- Reinstall the wheel-and-tire assembly and torque the wheel nuts to the proper specification.
- Repeat the procedure on other rotors as required.

Break-In/Burnishing

Many vehicle and brake component manufacturers recommend performing a brake pad break-in/burnishing procedure to condition the brake pads and rotors following the installation of new brake pads. Common recommended brake pad break-in/burnishing procedures include the following steps:

- Select a straight section of highway with a speed limit of 55 MPH or more and little traffic.
 - Perform 5 to 8 moderate brake applications from 40 to 10 MPH
 - Perform 5-8 rapid deceleration brake applications from 60 to 10 MPH
 - Drive 1.5 to 2 miles (allow the brakes to cool)
 - Perform 5-8 rapid deceleration brake applications from 60 to 10 MPH

Note: Some brake smoke and odor may result from the break-in/burnishing procedure; this should be considered normal.

Unit 5: Power Assist Systems

Chapter 1: Power Assist Systems Overview and Diagnosis

Vacuum Assist Booster System

A vacuum is a condition in which the pressure of a specific area is less than the surrounding atmospheric pressure. This pressure differential can be manipulated using a diaphragm, which is a flexible membrane that reacts to different pressures while preventing pressures from interacting.

Vacuum-boost power brake systems use the difference between the engine manifold vacuum (a negative pressure within the intake manifold) and atmospheric pressure (which is approximately 14.7 pounds per square inch (psi)) to provide power for brake applications.

Note: On engines that do not have high manifold vacuums, such as diesel and gasoline engines with high performance packages, a vacuum pump usually provides a vacuum for the power brake system.

The two types of vacuum boosters used on modern vehicles are the single-diaphragm and the tandem-diaphragm (or dual-diaphragm) booster. Both booster types operate similarly but the tandem-diaphragm booster is smaller in diameter and is used on vehicles where space is critical.

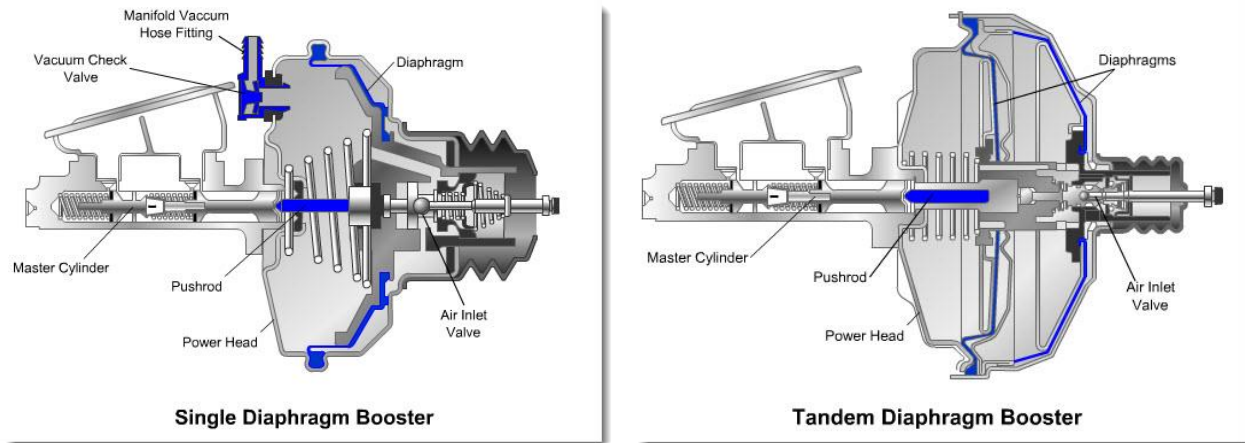

Vacuum Booster Operation

Note: We will be referring to a single-diaphragm vacuum brake booster in this example.

Vacuum boosters are mounted between the brake pedal pushrod and the master cylinder and receive engine vacuum through a hose and check valve (one way valve). The check valve holds vacuum pressure and assures power assist capability during times of low engine vacuum (i.e. the engine quits). With the check valve in place, a booster will have enough reserve vacuum for 2-3 brake applications after engine vacuum is lost. Vacuum boosters operate as follows:

When the brake pedal is released, an internal vacuum port is open which allows engine vacuum to flow from the check valve to both sides of the diaphragm. With equal pressure (vacuum) on both sides, the diaphragm is held to the rear by spring pressure.

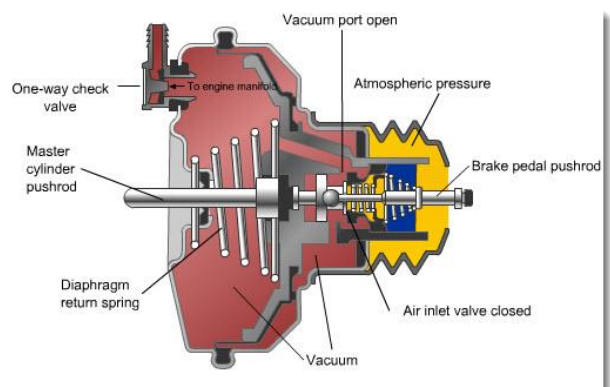

As the brakes are applied, the brake pedal pushrod moves forward, which closes the vacuum port and opens the air inlet valve. This action seals off the backside of the diaphragm from the vacuum source and at the same time allows filtered atmospheric air pressure to pass through the air inlet valve to the diaphragm backside. The combination of atmospheric pressure on the backside and vacuum on the front side then moves the diaphragm and master cylinder pushrod forward to apply the brakes.

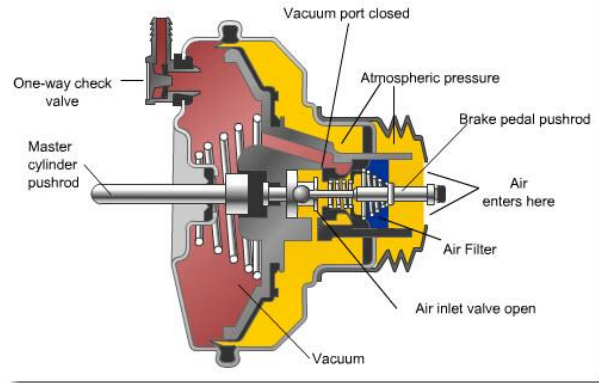

Hydraulic Assist Booster System

Hydraulic brake assist systems are used on many vehicles with limited space under the hood or vehicles with engines that cannot consistently produce sufficient vacuum to operate a vacuum power boost system. These include:

- Diesel engines
- Turbocharged engines
- Engines that operate at high load (low vacuum) such as truck applications.

The most common type of hydraulic-assist system uses pressure from the power steering pump to provide power brake assist. Power steering pump pressure is used to help apply the brakes and also to charge an accumulator - a chamber that holds a supply of fluid or gas under pressure - for engine-off assist.

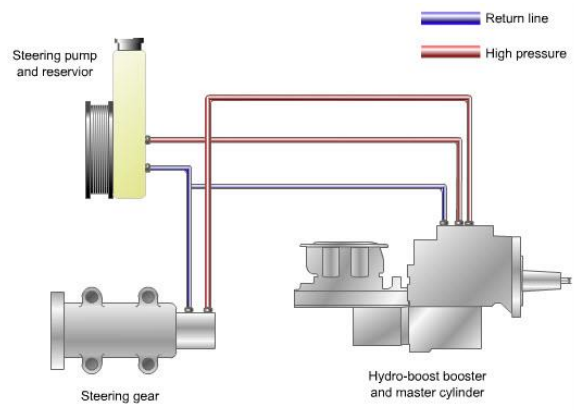

When hydraulic pressure fills an accumulator, it pushes a rubber seal against a piston and collapses the internal spring. If the power steering pump stops (the engine quits), the spring will expand and push the fluid into the booster for braking assist. Accumulators can typically provide sufficient (emergency) hydraulic pressure for two or three (2 or 3) brake applications if power steering pressure is lost.

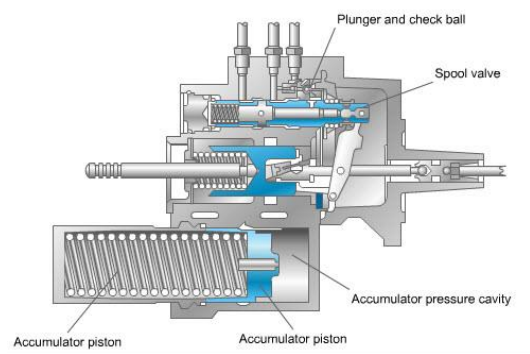

Diagnosing Hydraulically-Assisted Power Brakes

Hard pedal

Note: Hard pedal may develop due to problems unrelated to the power assist system. Check the general braking system first.

- Check for a loose or glazed power steering belt. A problem in the power steering system can cause trouble in the power brake system. Check the power steering fluid level. Check for kinks or pinches in the power steering pump hoses. Make sure the power steering is functioning properly.
- Check for external leakage in the brake hydraulic system.
- Check the power booster for defects. Repair or replace the booster as necessary.

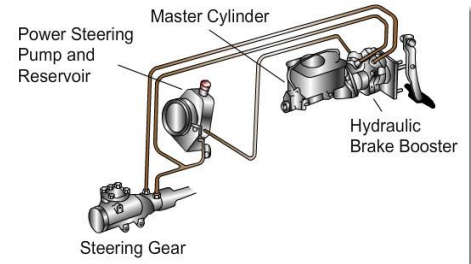

Unit 6: WHEEL BEARINGS, PARKING BRAKES, AND BRAKE LIGHTS AND CIRCUITS

Chapter 1: Wheel Bearings

Wheel Bearing Service and Adjustment

The wheel bearings are normally serviced when brake repair work is done. Use proper lifting equipment to raise the vehicle when servicing wheel bearings.

CAUTION: When lifting a vehicle, always use proper lifting equipment and observe all safety precautions.

Special tools are available for removing the hubcap. Wheel bearing packers can also be used to force grease into the wheel bearing. For most wheel bearing service, however, a torque wrench and common hand tools are sufficient.

There are many brands of quality wheel bearing lubricants on the market. Always use a high-quality wheel bearing grease. A wheel bearing grease that is identified as suitable for use in disc brake systems is usually acceptable for all applications.

Some wheel bearings on late-model front-wheel-drive vehicles are not serviceable. Do not attempt to lubricate non-serviceable bearings. If the bearing is defective, replace the entire bearing assembly. In some cases, it may be necessary to replace the entire knuckle. Serviceable wheel bearings typically have scheduled service intervals ranging from 20,000 miles to 30,000 miles under normal driving conditions.

Inspecting and Servicing Nonsealed Wheel Bearings

Note: Before servicing a wheel bearing, determine whether the bearing is sealed or nonsealed. Although most four-wheel-drive vehicles use sealed bearings, the bearings are individually serviceable once they are removed. Consult the procedures in the proper service information for inspecting and replacing these bearings.



Procedure for inspecting nonsealed wheel bearings

Use proper lifting equipment to raise the vehicle.

CAUTION: When lifting a vehicle, always use proper lifting equipment and observe all safety precautions.

- Spin the wheel. The wheel should turn freely without binding or making any noise.
- Grasp the wheel by the top and bottom of the tire and try to move it in and out. The wheel should move slightly (.001 in to .005 in as measured by a caliper on the drum or rotor).

If spinning the wheel and moving the tire in and out reveal no problems, then no other inspection is required. However, if the bearings are not noisy but are slightly loose, adjustment may be necessary. If the bearings are noisy or excessively loose or tight, then the bearings need servicing.

Procedure for Servicing Nonsealed Wheel Bearings

- Use proper lifting equipment to raise the vehicle.

CAUTION: When lifting a vehicle, always use proper lifting equipment and observe all safety precautions.

- Remove the wheel.
- Encapsulate the brake assembly and remove all asbestos dust.

CAUTION: Asbestos is a cancer-causing substance. Do not breathe asbestos dust or allow it to escape into the air.

- Remove the brake caliper or drum. If it is not necessary to service the caliper at this time, leave the hydraulic hose connected. If the hydraulic hose is left connected, be sure to prevent the caliper from hanging on the hose.
- Examine the hub assembly. Look for a dust cap at the center of the hub.
- Remove the dust cap.

Note: If a dust cap is not present, the wheel bearings are not adjustable.

- Remove the cotter pin from the spindle nut.
- Remove the spindle nut. Carefully remove the washer and the outer wheel bearing from the center of the wheel.

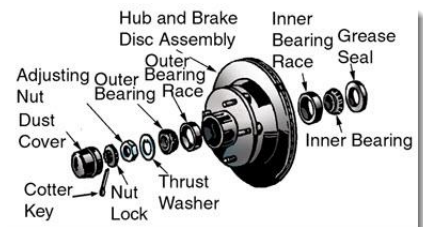

CAUTION: Do not drop the bearing.

- Slide the hub assembly off the spindle.

CAUTION: Do not place fingers on the friction surface of the brake. Do not allow the hub assembly to drag heavily across the spindle threads.

- Using a brass or wooden drift, reach through the hub and tap the inner grease seal out of the hub.
- Remove the inner wheel bearing.
- Using a clean shop towel, wipe the grease out of the hub. Avoid getting grease on the friction surfaces of the brake.

Note: If the rotor is in two pieces, work on the hubs with the friction disc removed.

CAUTION: Keep all wheel bearings in sets and return them to the same spindle they were taken from. Do not replace defective wheel bearings with used wheel bearings.

- Thoroughly wash the wheel bearings and all of the parts removed with them in solvent.
- Use compressed air to blow all old grease out of the bearings.
- Make sure to remove all grease from the inside of the bearings.
- Rewash and dry the bearings and accompanying parts.

CAUTION: Do not allow the bearings to spin on the finger(s) while blowing the bearings dry; doing so may result in personal injury.

- Examine each bearing carefully and note any imperfections such as chips, pits, scratches, etc. Also examine bearings for discoloration, which indicates overheating. If any problems are found, replace the bearings.

Note: Always replace each bearing and its race if there is any doubt about its condition.

- Repack each bearing with fresh grease by manually pushing it into the larger side of the bearing assembly until it forces out of the bearing.

Note: Make sure the bearings are repacked with a grease that is designed to withstand the high temperatures and extreme pressures to which the bearings are exposed.

- Place the equivalent of 3 tablespoons to 4 tablespoons of grease in the center of the hub.
- Install the inner wheel bearing and a new grease seal.
- Carefully slide the hub assembly onto the spindle.
- Install the outer wheel bearing, washer, and spindle nut.

CAUTION: If solvent or grease gets on the drum or disc friction surface, clean the surfaces with an acceptable brake-cleaning solvent.

- Adjust the bearing. Procedures for bearing adjustment are described later in this lesson.
- Reassemble the remaining brake and wheel assembly components.

Inspecting and Servicing Sealed Bearings

Procedure for inspecting sealed wheel bearings

- Use proper lifting equipment to raise the vehicle.

CAUTION: When lifting a vehicle, always use proper lifting equipment and observe all safety precautions.

- Spin the wheel. The wheel should turn freely without binding or making any noise.
- Grasp the wheel by the top and bottom of the tire and try to move it in and out. The wheel should move slightly (.001 in to .005 in as measured by a caliper on the drum or rotor).
- If spinning the wheel and moving the tire in and out reveals no problems, then no other inspection is required. If the bearings are noisy or excessively loose or tight, then it is probably necessary to replace the bearing.

Procedure for removing and replacing sealed wheel bearings

Procedures for removing and replacing sealed wheel bearings vary greatly. Refer to the proper service information for the procedure that applies to the vehicle to be serviced.

- Notes:**
- Some front-wheel-drive vehicles may have wheel bearings that are incorporated into the knuckles. This design requires removing the drive axles and bearings from the knuckle. See the proper service information for this procedure.
 - Most sealed wheel bearings are nonadjustable.

Procedure for Tightening Sealed Wheel Bearings

Note: Sealed bearings are tightened, not adjusted. Most four-wheel-drive or front-wheel-drive vehicles have sealed bearings.

- If a sealed bearing makes noise or does not turn smoothly, disassemble the entire unit in order to evaluate the bearings and replace them if necessary.
- If it is necessary to replace sealed bearings, adjust (or tighten) the new bearings according to the manufacturer's specifications.
- Procedures for adjusting (tightening) sealed bearings vary from vehicle to vehicle. Consult the proper service information for the correct procedure.

Note: Some Chrysler and foreign front-wheel-drive vehicles use bearings that cannot be adjusted even though they are not sealed. If these bearings make noise or fail to turn smoothly, disassemble the entire unit in order to evaluate and pack the bearings.

- Inspecting and Replacing Wheel Studs
- Inspect the wheel studs.
- Raise the vehicle and remove the lug nuts.

CAUTION: When lifting a vehicle, always use proper lifting equipment and observe all safety precautions.

- Inspect each wheel stud. Look for signs of wear or damage. Check for bent or loose studs.

CAUTION: For safety reasons, all damaged or worn studs should be replaced.

- Replace the wheel studs.

Note: Because of variations in vehicle designs, there are a number of different service procedures used to replace wheel studs. The following is a general procedure. Be sure to locate the correct procedure for the vehicle.

- Remove the lug nuts and wheel.
- Remove the brake rotor/drum and hub assembly.

Note: On some vehicles, it is not possible to remove the hub.

- Press the damaged studs out of the hub assembly.
- Inspect the stud-mounting area of the hub for damage or wear.
- Insert the new studs and press to set.
- Install the hub assembly, brake rotor/drum, and wheel.
- Install and torque the lug nuts to specifications.

Chapter 2: Parking Brakes and Brake Light Systems

Parking Brake

Federal Motor Vehicle Safety Standards require that automotive parking brakes be capable of holding a vehicle stationary on a 30 degree grade. The parking brake systems on most vehicles use either a hand or foot operated lever and cables to mechanically apply the rear wheel brakes.

Typical parking brake system

The parking brake operates independently of the hydraulic service brakes. When the lever activates, the cables to the rear brakes stretch tightly and lock the brake against the friction surface.

In some parking brake systems, a vacuum motor releases the parking brake when the transmission shifts out of park. In other systems, the driver manually releases the parking brake.

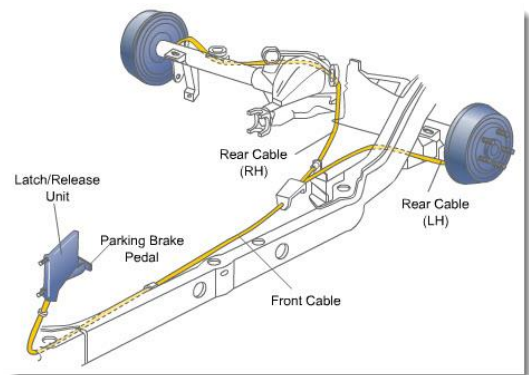

Mechanical Brake System Components

Pedal mounts or hangers are the fixtures upon which the brake pedal is mounted. The clutch pedal is often mounted like the brake pedal. The hanger includes the bushings and bearings upon which the pedals swing. Manual transmission vehicles include a switch on the hanger that prevents starter engagement unless the driver depresses the clutch pedal. These hangers have another switch on the brake pedal to control the brake lamps.



Various cables, levers, struts, and linkages connect the parking brake system to its operating lever or handle.

Parking Brake - Drum (Duo-Servo)

When a driver applies the parking brake on a vehicle equipped with rear drum brakes, it pulls cables that are attached to actuator levers and struts inside the brake drum. These actuator levers and struts mechanically apply the brakes by pushing both brake shoes outward into the drum. When the brake releases, a spring on the parking brake strut recenters the shoes in the drum. Parking brake strut and actuator lever (duo-servo)

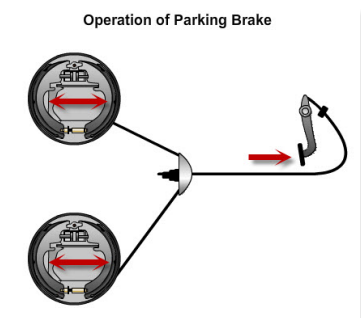
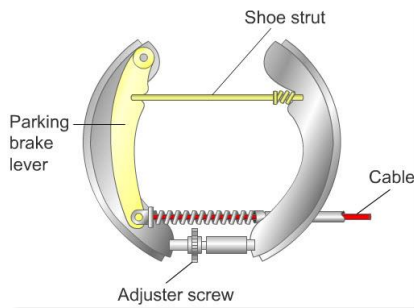

Disc Brakes with Integral Parking Brake

Many vehicles that are equipped with rear disc brakes require a regular application of the parking brake to keep the rear disc brakes in proper adjustment. Unlike front disc brakes, rear disc brakes on these vehicles are not self-adjusting. The two most common types of caliper-actuated parking brakes are the:

- Screw-and-nut
- Ball-and-ramp

Screw and Nut Parking Brake

When the parking brake is applied on a rear-disc-equipped vehicle the following occurs:

- The cable actuated parking brake lever rotates an actuator screw.
- The actuator screw unthreads on a nut inside the piston.

- As the screw turns, it moves the nut outward by pressing against a cone inside the piston.
- The piston applies the inboard pad against the rotor. The movement of the piston also causes the caliper assembly to slide and apply the outboard pad.
- An adjuster spring inside the nut and cone rotates the nut outward when the parking brakes are released to provide self-adjustment. Rotation of the nut also takes up clearance as the brake pads wear.

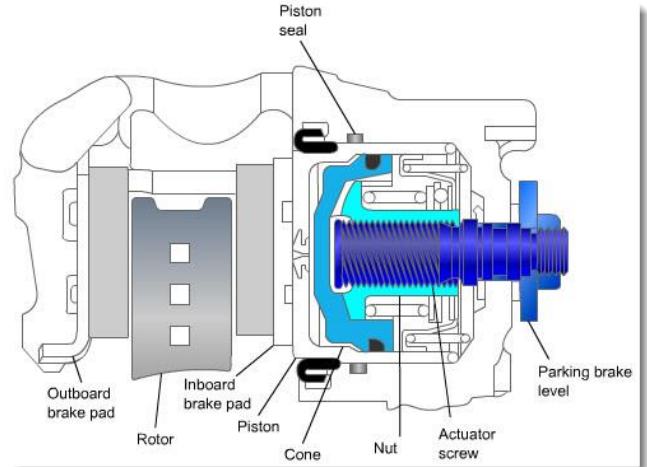

A GM screw-and-nut parking brake mechanism

Ball-and-Ramp Parking Brake

In the ball-and-ramp park brake system, the caliper lever is attached to a shaft inside the caliper that has a small plate on the other end. A second plate is attached to a thrust screw inside the caliper piston.

Three steel balls separate the two plates.

When the parking brake is applied, the caliper lever rotates the shaft and plate. Ramps on the surface of the plate force the balls outward against similar ramps in the other plate. This action forces the thrust screw and piston outward applying the brake. When the park brake is released, an adjuster nut inside the piston rotates on the thrust screw to take up excessive clearance and provide self-adjustment.

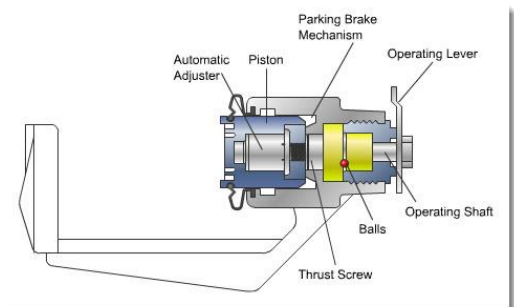

A Ford ball-and-ramp parking brake mechanism

Drum-In-Hat Parking Brake

Some later model vehicles with four wheel disc brakes use a small drum brake incorporated into the rear rotor called a drum-in-hat system. This system consists of a simple, cable activated shoe assembly that applies against a drum machined inside the rotor hat section. With a drum-in-hat parking brake, the rear caliper does not have to perform both service and parking brake functions. The parking brake shoes for this system are manually adjusted when installed and, theoretically, should never need readjustment.

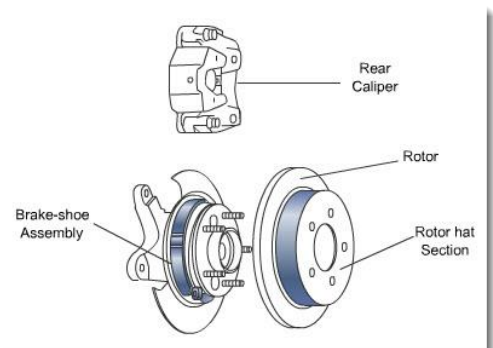

A drum-in-hat parking brake

Note: Kinked or binding parking brake cables or linkages could prevent a parking brake from applying or releasing properly. This could also cause the brake warning light to remain on even after the parking brake is released.

Testing Parking Brake Performance

- Place the vehicle on a slope with the front of the vehicle pointed down slope.
- Set the parking brake, place the transmission in neutral, and slowly release the hydraulic brakes.
- Turn the vehicle around with the front pointing up the slope.
- Set the parking brake, place the transmission in neutral, and slowly release the hydraulic brakes.

Inspecting and Adjusting Drum Parking Brakes

Procedure for inspecting integrated parking brakes

- Make sure the cables and linkages work freely and are in good physical condition; check the cables especially closely for fraying.
- Make sure the parking lever and strut operate properly and exhibit no signs of excessive wear. Also make sure the components are assembled properly.
- Inspect the activating components of the parking brake. Check all friction surfaces of each brake shoe for thickness and contamination.



Note: Remove the brake drum before inspecting the activating components and friction components of the integrated parking brake.

- Repair the components as necessary.

Procedure for inspecting auxiliary drum parking brake

- Remove the rotor/drum from the rear axle.
- Inspect the activating components of the parking brake.
- Check all friction surfaces of each brake shoe for thickness and contamination.
- Repair the components as necessary.

Procedure for adjusting integrated and auxiliary parking brake systems

- Make sure the parking brake is off. Adjust the brakes to make sure the resting clearance (adjustment) is correct.
- Engage the parking brake lever (pedal handle) two notches.
- Use proper lifting equipment to raise the vehicle.

CAUTION: When lifting a vehicle, always use proper lifting equipment and observe all safety precautions.

- Reduce or increase the slack in the parking brake cables by moving the equalizer up or down the adjustment rod.
- Turn the equalizer nut one turn at a time to increase or reduce cable slack. After each turn of the nut, try to spin the rear wheels.
- When the parking brake is adjusted correctly, there is a slight drag on the wheel-and-tire assembly. After feeling the slight brake drag, release the parking brake lever.

- To ensure the parking brake is adjusted correctly, make sure the wheels spin freely.

Inspecting and Adjusting Disc Parking Brakes

Note: Because the activating device is located inside the caliper, inspection can occur only if the caliper is disassembled. To inspect the activators in these systems, consult the correct service information.

- Visually inspect the thickness of the friction material by looking through the caliper to determine the thickness of the brake pads. Determine necessary action.
- Completely disengage the parking brake. Use proper lifting equipment to raise the vehicle.

CAUTION: When lifting a vehicle, always use proper lifting equipment and observe all safety precautions.

- Make sure the cable levers on the calipers are on their off stops.
- Adjust the cable length at the equalizer.
- When the brake is adjusted correctly, it should give about 15 clicks (notches) of travel with approximately 150 lbs. of force.

Testing Brake Lights and Circuits

Testing the Parking Brake Indicator Light

- Turn the ignition switch to the run position.
- Observe the indicator light while setting and releasing the parking brake. Note whether the light goes on when the brake is applied and goes off when the brake is released.

Testing the Brake Light Circuit

Brake lights illuminate when the brakes are applied warning other drivers that the vehicle is slowing down or stopping. A switch, usually located at the brake pedal, controls the brake light circuit. Sometimes the switch is hydraulically activated when the brake system is pressurized.

The lights are always at the rear of the vehicle. There may be as few as two or as many as seven brake lights. On many newer vehicles, a single "Cyclops" brake light is mounted high and centered at the rear of the vehicle. The Cyclops brake light is usually mounted inside the vehicle and shines out through the rear window. The battery powers the brake light circuit. This circuit receives power even when the ignition switch is off.

Procedure for testing the brake lights

- Test the brake light switch. Have an assistant depress the brake pedal and observe the brake lights at the rear of the vehicle. If all the lights are on, the switch is operating normally.
- If some of the lights are on and some are not, check the bulbs on the lights that are not functioning.
- If all the lights on one side are inoperative, check the directional signal switch on the inoperative side.
- If the brake lights are not functioning even though the bulbs are operational, inspect the brake light switch using the following procedure.

- Locate the brake light switch near the brake pedal and unplug the connected wire. Connect a jumper wire between its terminals.
- If the light comes on, replace the switch.
- If the light still does not come on, look for faults in the brake light wiring.
- Testing the Brake Stop Light System
- To check the operation of the brake stop light system, have an assistant depress the brake pedal and observe the brake lights at the rear of the vehicle. If all brake lights are on, the system is working normally. If no brake lights are illuminated it will be necessary to test components to locate the concern. Start by reviewing service information and wiring diagrams. Test the fuses related to the brake light systems.

Note: if one or more fuses are blown, replacing the fuse(s) may not correct the concern.

- Inspect and test the brake light switch test for battery power to the switch and power out of the switch with the brake pedal depressed. If there is power to the switch but no power out with pedal depressed the switch may be defective and should be replaced.
- If, when the brake pedal is depressed, some of the brake lights are on but others are not, check the bulbs on the lights that are not functioning. Next check for power and test the ground circuit to the bulb. If all the lights on one side are inoperative, check the directional signal switch on the inoperative side.

Unit 7: Abs and Traction and Stability Control Systems

Chapter 1: Systems and Components

Overview of Antilock Brake Systems

An ABS helps the driver maintain control of the vehicle when braking. If the wheels lock during braking, the vehicle may slide out of control. The antilock system prevents the brakes from being applied hard enough to lock the wheels.

In an ABS, electronic sensors detect the signs of individual wheels locking up and modify brake application at the individual wheel accordingly. The ABS may modify brake applications very rapidly - up to 15 times a second.

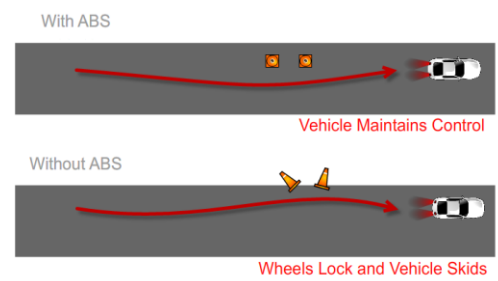

An ABS does not help maintain vehicle control during hydroplaning or radical steering maneuvers. During **hydroplaning**, the vehicle's tires ride on a film of water and thus separate from the road surface. Hydroplaning may cause the driver to lose control; antilock brakes cannot correct hydroplaning. Antilock brakes cannot prevent or correct skids that result from radical steering maneuvers or high-speed cornering.

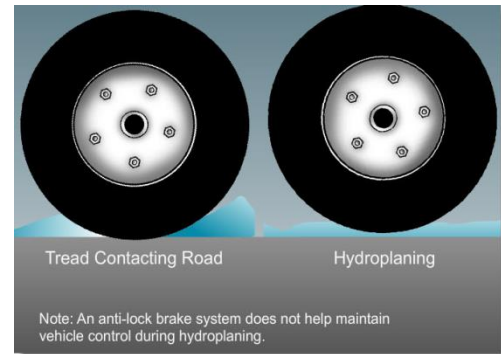

Some antilock systems include traction control or vehicle stability control systems.

- **Traction control systems** rapidly apply and release the vehicle's brakes to reduce wheel spin and add traction during rapid acceleration.
- **Vehicle stability control** systems automatically and selectively apply the brakes as needed to help keep the vehicle on its intended course.

Antilock Brake System Components

An ABS uses many of the components of a conventional braking system. The components are a brake booster, master cylinder, brake lines, wheel cylinder/calipers, brake drums/rotors, and brake pads/shoes. The unique components in an ABS include speed sensors, a modulator, and a controller.

Speed sensors

Speed sensors are electromagnetic devices that determine wheel speed or drive line speed. The speed sensor includes a toothed ring and a magnetic pickup coil.

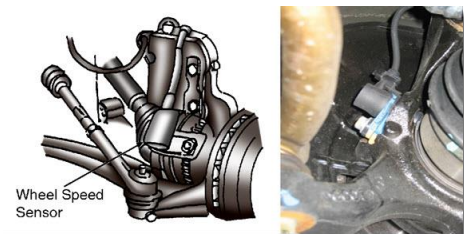

The **toothed ring** is mounted on a rotating component.

The **magnetic pickup coil** is stationary and is mounted close to the rotating toothed ring.

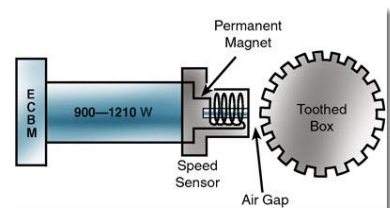

As the toothed ring rotates, it induces a voltage in the pickup coils. As the wheel speed increases, so does the rotating speed of the toothed ring. The voltage produced in the coil is proportional to the speed of the wheel. The ABS controller senses this voltage.

Brake Modulator

This device functions to prevent wheel lockup and skidding by adjusting the amount of hydraulic pressure that is fed to the brakes. The ABS controller controls the brake modulator. Depending on the vehicle year and manufacturer, the ABS controller has different names, such as ECU, ABCM, EBCM, and CAB. The most basic brake modulator control valve is two valves in one: a dump/decay valve and an isolation/build valve.

ABS Controller

This component controls the dump/decay valve and the isolation/build valve (both comprise the control valve). The ABS controller causes the control valve assembly to either maintain the same amount of hydraulic pressure, release hydraulic pressure through the dump valve, or increase brake pressure. Essentially a microcomputer, the ABS controller receives signals from the speed sensors. When a wheel speed sensor indicates an impending skid, the controller closes a valve. When the valve closes, fluid is prevented from coming into the braking circuit, thus preventing the problem wheel from decelerating further.



ABS Controller Assembly



Side View

The controller then analyzes the sensor signals from the problem wheel once again. If that wheel continues to decelerate, the controller opens the dump valve and releases whatever pressure is trapped in the brake circuit. This again prevents further deceleration.

Once the problem wheel regains an acceptable speed, the controller returns the valves to their normal position. When the valves are in their normal position, fluid flow returns to the problem wheel's brake. The controller also monitors the electromechanical components of the system. If a problem arises with the electromechanical components, the controller closes down all or part of the system.



Note: Even when the antilock system closes down, normal power-assisted braking remains. A warning light located in the instrument panel indicates problems.

Variations in the Antilock Brake System Design

Most antilock systems are designed for all four wheels. Some systems, such as GM's RWAL, are designed only for the rear wheels.

The RWAL uses an antilock pressure valve located under the master cylinder to regulate the rear hydraulic brake line pressure.

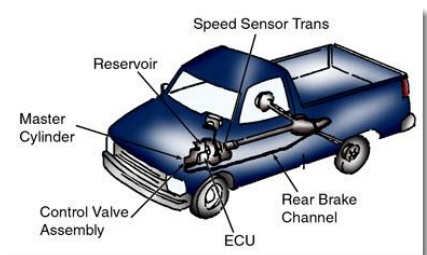

The antilock pressure valve is two different valves in a single assembly: a dump valve that relieves rear brake pressure and an isolation valve that maintains rear brake pressure. A microprocessor in the electric brake control module, usually mounted next to the master cylinder valve, controls the valve.

During hard brake application, the control module causes the valve to perform one of three functions: the module allows the valve to maintain its current level of hydraulic pressure; the module causes the dump valve to release hydraulic pressure; or the module pulses the isolation valve to increase hydraulic pressure. A VSS, which is located in the transmission or rear axle housing, sends signals to the control module.

Integrated Hydraulic Assembly Design

The integrated hydraulic assembly design is named for how the components are arranged.

The **integrated assembly** is a compact unit consisting of a booster/master cylinder, modulator, hydraulic bladder accumulator, fluid reservoir, and in some applications an electro-hydraulic pump.

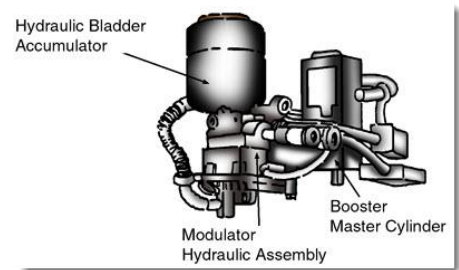

The electro-hydraulic pump delivers brake fluid under high pressure - 2,000 psi (pounds per square inch) to 2,600 psi - to the accumulator. The accumulator performs the following functions:

- Acts as a holding tank for the pressurized fluid
- Provides the booster with the necessary hydraulic pressure for a normal power assist
- Supplies the rear brake circuit with hydraulic pressure during both conventional and antilock braking

If the pump fails, the accumulator holds enough pressurized fluid to provide up to 20 power-assisted stops. The accumulator therefore acts as a safety device. The controller monitors, compares, and analyzes the input from four WSSs. If one wheel decelerates quicker than the others, the controller releases pressure at the wheel (the problem wheel). If a wheel accelerates too quickly, the controller reopens the inlet valve. This causes accumulator pressure to apply the brakes. This process happens up to 15 times a second.

Nonintegrated System Design

The nonintegrated system design is much cheaper to produce and install than an integrated system. This is because it uses the conventional master cylinder and power booster, which can be added easily onto a vehicle's brake system.

Some nonintegrated systems use solenoid-operated, three-position, spring-loaded valves to control each brake circuit. During normal power-assisted braking, these valves remain open, allowing the brake fluid to pass through on its way to the calipers and wheel cylinders. When hard braking occurs, the controller senses if one wheel decelerates quicker than the others. The controller then moves the valve into its second position. This cuts off the pressure from the master cylinder and holds the pressure constant in the brake circuit to



the caliper or wheel cylinder.

If the wheel still slows down too fast, the controller moves the valve to its third position. This releases pressure from the brake circuit and allows the fluid to flow to a return pump, which moves the fluid back to the master cylinder. If the wheel speeds up too much, the controller reopens the valve, allowing fluid pressure from the master cylinder back into the brake circuit. The hold-release-apply cycle occurs 4 times per second to 10 times per second.

Other System Designs

Some vehicle manufacturers tailor antilock brake systems to meet their specific needs. Some vehicles use nonintegrated systems in which a lateral acceleration signal indicates to the ABS controller that the vehicle's rear wheels are turning too fast. The controller modifies the antilock operation to keep the rear tires from skidding. Some systems use a deceleration sensor and a VSS to modify antilock operation.

Some antilock brake systems are three- or four-channel systems. Three-channel systems control the front wheels independently while the rear brakes are controlled on a common circuit. These may have a speed sensor at each wheel or have one for each front wheel and a third on the drive line to monitor the rear wheels as a pair. Four-channel systems require speed sensors for each wheel and thus control each wheel independently.

Note: Some antilock systems have built-in diagnostic capabilities in their computer. Diagnosis of the system is relatively simple, but repairs and adjustment require the appropriate service information and special diagnostic equipment.

Traction Control System Function and Components

Traction control systems work with the ABS to reduce wheel spin and add traction during rapid acceleration. Some traction control systems use separate hydraulic valve units and control modules from the ABS and some use the same components as the ABS. Common components of a traction control system:

- Speed sensors at the front and rear wheels
- ABS relays
- TCC/antilock brake switch
- Electronic brake and traction control module (EBTCM)
- Pressure modulator valve assembly
- Light in dash to indicate system operation

Stability Control System Function and Components

Stability control systems work with the ABS and traction control system to help improve vehicle control, particularly during steering. The system uses a microcomputer to compare the driver's intended path, which is determined by a steering wheel sensor, with the vehicle's actual path, based on information from additional sensors. When the system senses a difference between the vehicle's intended and actual path, it applies the brakes to the specific wheels needed to bring the vehicle back on course. Common components of a vehicle stability control system:

- Microcomputer to process information from the system's sensors
- Steering angle sensor to determine steering wheel position
- Wheel speed sensors located at each wheel
- Yaw sensor to determine the vehicle's movement around its vertical axis
- Lateral acceleration sensor to determine side-to-side movement

Chapter 2: Antilock Brake System Diagnosis and Service

Precautions and Normal Functions

Characteristics Unique to Antilock Braking Systems

In most cases, the pads, shoes, drums, rotors, mounting hardware, and bearings on antilock brake systems (ABS) are serviced in the same manner as on conventional brake systems. Many ABS problems are caused by speed sensor air gaps that are out of specification or electrical connections that are loose or corroded.

Precautions for Servicing Antilock Brake Systems

CAUTION: Failure to observe these precautions may result in personal injury and damage to the system. The following are general precautions. Use the procedures in the correct service information when servicing antilock brake systems.

- Disconnect the battery and powertrain control module (PCM) when arc welding on the vehicle.
- Antilock systems operate at very high pressures. Always depressurize the accumulator before servicing the ABS.
- To protect the control module, never disconnect or connect any ABS connector while the ignition switch is on.
- Never use a conventional 12-volt test light to probe the circuits. Antilock systems operate at very low system voltages; therefore, a conventional 12-volt test light can damage the antilock components. Use a high-impedance digital multimeter (DMM) to probe the circuits as indicated in the correct service information.
- Many ABS components are not serviceable; replace them as an assembly. Do not disassemble any ABS component that is not designed to be serviced.
- Brake fluid damages painted surfaces. If brake fluid is spilled on any painted surface, wash it off with water immediately.
- Some brake parts contain asbestos fibers that can become airborne as dust during brake service. Follow the latest federal procedures when working with asbestos.

CAUTION: Asbestos is a cancer-causing substance. Do not breathe asbestos dust or allow it to escape into the air.

- When working with ABS wiring, never touch the electrical connections or pins or allow them to contact brake fluid. This kind of contact damages the PCM.
- Follow the correct service information carefully.

- Using the wrong sequence of steps, skipping steps, or using the wrong service information leads to unnecessary replacement of parts.
- Before test driving a vehicle with a brake problem, test the brakes at a low speed to be sure the car stops normally.
- Use the manufacturer's specific procedure for bleeding the brakes on vehicles equipped with ABS. Procedures vary greatly from system to system.

Recognizing Normal ABS Functions

Some ABS functions may seem to be a sign of a problem when actually they are a normal part of ABS operation.

Noises

Some ABS-equipped vehicles have "BITE," which stands for "Built-In Test Equipment." BITE activates when the vehicle starts or after it reaches a designated speed. BITE produces a short series of clicking, popping, groaning, or growling sounds. The antilock system makes these noises as the computer tests it. These noises are also produced during antilock stops.

Pedal pulsation

Brake pedal pulsation is often a sign of warped rotors or out-of-round drums. On some antilock systems, however, pedal pulsation is a normal occurrence during antilock braking. In some antilock systems, brake pedal pulsation occurs when the driver applies the brakes and then releases the brakes very rapidly.

Pedal drop

In some systems, the pedal may drop slightly during antilock braking. This occurs as the accumulator relieves hydraulic pressure by temporarily taking fluid out of the hydraulic system.

Diagnosing Antilock Brake Systems

Note: Procedures for diagnosing problems in antilock systems vary greatly depending on the specific system. Although some systems may appear identical, use only the diagnostic and service procedures that the manufacturer of the system recommends. If the visual inspection reveals no problems, consult the proper service information for more detailed procedures.

Begin diagnosing an antilock brake system with a thorough visual inspection of the entire system.

- Check the brake fluid level.
- Check the system fuse(s).
- Check all of the system's electrical connections. Make sure the ground connections are tight and corrosion free and the hydraulic lines and connections are in good condition. Check the diodes in the system's wiring harnesses. Refer to the appropriate service information for the test procedures and location of the diodes.

Service on most antilock systems requires the use of special tools, such as a high-impedance DMM, a set of pressure gauges, a scan tool with the proper software, a digital storage oscilloscope (DSO) or graphing multimeter (GMM), and a breakout box.

A high-impedance DMM is used because the multimeter becomes part of the circuit it is testing; therefore it is important that the DMM not increase the current draw enough to damage the component being tested.



CAUTION: Some components should not be tested directly, even with a high-impedance DMM. Use only the diagnostic and service procedures that are appropriate for the make and model of vehicle being serviced.

DSOs and GMMs graph changes in voltage over time using a waveform. Because they provide a continuous readout over a period of time, a DSO or GMM can show abrupt changes or intermittent problems other diagnostic equipment might miss.

Some systems may require using a breakout box to perform pin-out checks. For some systems, it may be necessary to access the electronic trouble codes stored in the PCM via a scan tool. For other systems, it may be necessary to read the flash codes in the form of flashes from the system warning light. Most service information provides flowcharts to help identify the system problems precisely.

Diagnosing Intermittent Electrical Problems

Note: Standard diagnostic procedures may not help to determine the cause of intermittent electrical problems in the antilock system. In most cases, the fault must be present to locate the problem using a diagnostic chart. Faulty electrical connections or wiring causes most intermittent problems.

Make sure the connector halves are properly mated and the terminals are fully seated in the connector body. Check for improperly formed or damaged terminals. To increase the electrical contact, carefully reform all connector terminals in a problem circuit. Make sure there are no poor terminal-to-wire connections. Remove the terminal from the connector body to inspect it. If the visual check does not find the cause of the problem, test drive the vehicle and try to duplicate the condition.

CAUTION: Always obtain permission from the instructor before road testing and test for braking before moving the vehicle.

Servicing Individual ABS Components

Servicing speed sensors

Visually inspect the speed sensors. Check the toothed wheel for missing or broken teeth. The toothed wheel should show no evidence of contact with the wheel speed sensor. If there has been contact, determine the cause and correct it. Check the toothed wheel for excessive runout. Excessive runout can cause erratic wheel speed signals. Replace the assembly if runout exceeds the manufacturer's specifications.

Note: If the cables are not correctly installed in their retainers, they may contact moving parts and/or become overextended. This may create an open circuit. In addition, if the sensor cables are routed incorrectly, other conductors positioned too closely to the sensor cables may induce false voltage signals.

For the antilock system to function correctly, the vehicle's tires and wheels must be the proper size and type. Use only the tire size that the manufacturer recommends. Tire size is important because antilock systems operate according to wheel speed signals. Inaccurate signals may result from improper wheel size and tire size or improper inflation pressures.

Powertrain control module (PCM)

Note: The PCM is not serviceable and must be replaced if defective. Some service procedures can involve the PCM.

Service precautions regarding the PCM:

- When testing for open or short circuits, never ground or apply voltage to any of the circuits unless the appropriate service information specifically instructs doing this.
- Never pierce connectors or wires; doing so breaks the seal and results in a poor connection.
- Never apply or cut off power to a control module while the ignition is in the on position.
- Interchanging PCMs from one vehicle to another may change the braking distance and make the vehicle unsafe. When replacing parts, use only components that the manufacturer specifically recommends.

Accessing PCM memory:

- Antilock systems with self-diagnostic capabilities store trouble codes in a nonvolatile memory.

- The PCM cannot recognize all system problems and failures. If memory codes or service codes cannot lead to a diagnosis, follow other procedures.
- The PCM also cannot store a service code if the module is not receiving any power.

Note: When servicing some antilock systems, trouble codes must be erased from the PCM memory after making repairs. In other systems, trouble codes automatically erase.

Warning lamps and brake system diagnosis

Many antilock systems use two lights: one marked BRAKE to signal problems in the normal brake system and the other to signal problems in the antilock system. To trace a problem to specific components, perform a warning lamp sequence test while observing when the lamps light up or count the blinks of the warning lamp.

Servicing a brake pedal travel switch

The **brake pedal travel switch** monitors the pedal position. The switch relays this information to the PCM. If the pedal travel switch is not adjusted properly or is not electrically connected, the pedal will not feel right. Most problems with the switch cause the pump to run during the entire ABS stop. During this time, the pedal becomes very firm, pushing up the driver's foot.

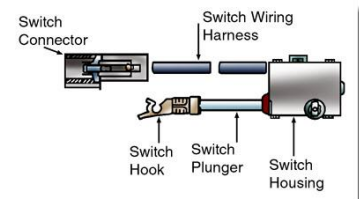

Hydraulic Assembly

The hydraulic unit involves several different components. When a problem develops in a component, the unit can sometimes be disassembled and the affected part repaired or replaced.

CAUTION: Some hydraulic assemblies are not serviceable and must be replaced when any of their components fail. Never disassemble any unit or component that the manufacturer has identified as non-serviceable.

During many hydraulic assembly tests, it may be necessary to disconnect the brake lines in order to connect a pressure testing gauge.

CAUTION: Depressurize the hydraulic accumulator before disconnecting any hydraulic tube or fitting. Failure to depressurize the accumulator may result in personal injury and/or damage to the vehicle.

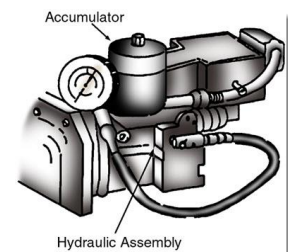

One procedure used on some ABS to depressurize the brake system requires turning off the ignition switch or disconnecting the battery cable. Then the brake pedal is pumped a minimum of 40 times. A noticeable change in pedal feel occurs when the accumulator is discharged.

CAUTION: The ABS pump/motor assembly keeps the accumulator charged to a pressure of up to 2,600 pounds per square inch (psi) any time the ignition is in the on position. Do not turn on the ignition any time the brake line is disconnected.

Regenerative Braking

Hybrid vehicles use the kinetic energy of the vehicle in motion to generate electricity. The electric motor(s) that are used to power the vehicle become electrical generators when the vehicle is decelerating.

When the driver pushes the brake pedal, a signal is sent to the onboard computer(s), but instead of applying the hydraulic brakes, the electric motor(s) are used to slow the vehicle. The wheels of the vehicle drive the electric motors, which generate electrical current that is sent to the hybrid storage battery and stored for later use to power the vehicle. In emergencies or high-speed stops, the vehicle's hydraulic brakes are used to slow the vehicle.

The components of the regenerative braking system include the onboard computer(s) used to control the hybrid and brake systems, the hybrid electrical motor(s), the hybrid electrical circuits, and the hybrid storage battery.